

TECH FOR SAFETY

BlueSupra™

Supra Digital Chips

2025



BlueSupraTM

Supra Digital Chips



13227 13243 13271 13273 13279



13248 13272 13226
13228 13221
13223 13282



13263 13236 13286 13287 13281



13285 13288 13283



53241 53282 53273 53279 53226
53228



53263 50732



1735 1762 1724

Universal Tag

Page	Item No.	
7	13227	SupraNano, Embedded Digital Chip.
9	13248	SupraNail, Embedded Digital Chip.
12	13243	SupraTag
14	13282	SupraLoop
16	13271	Supra HoseTag, 7mm
17	13273	Supra HoseTag, 16mm
18	13279	SupraRing
19	13272	SupraMini
20	13226	SupraBolt, M8x20mm
21	13228	SupraBolt, 5/16x3/4"
22	13221	SupraCastle, M10x20mm
23	13223	SupraCastle, 3/8x3/4"
26	13263	SupraPlate, Nameplate.
29	13236	SupraWeb, Web Sling Tag.
30	13286	SupraButtom, Web Sling Tag.
31	13287	SupraWireTag, Wire Rope Sling Tag
33	13281	Supra ChainTag, Chain sling Tag.
34	13285	Supra ChainTag, G80 Chain sling Tag.
35	13288	Supra ChainTag, G100 Chain sling Tag.
36	13283	SupraDA Tag, DNV Sling Tag.

ATEX Tag

Page	Item No.	
39	53241	Ex SupraTag, SupraX-241.
40	53282	Ex SupraLoop, SupraX-282.
41	53273	Ex Supra HoseTag, SupraX-273.
42	53226	Ex SupraBolt, M8x20mm, SupraX-226.
43	53228	Ex SupraBolt, 5/16x3/4" SupraX-228
44	53279	Ex SupraRing, SupraX-279
45	53263	Ex SupraPlate, SupraX-263.
46	50732	Ex Cable Tie. 1/2" x 11.8"

Reader

Page	Item No.	
48	1735	SupraTooth, Reader
49	1724	SupraPin, Reader
50	1762	SupraHana, Reader.



**TECH
FOR
SAFETY**





TECH FOR SAFETY



NFC Enabled

SupraNano, Embedded Digital Chip, the way to digitalization

SupraNano is the newest Digital Chip easily fitted into your product, ensuring optimal user experience, wherever and whenever people encounter NFC interactions.

The SupraNano can be easily embedded, readable in steel, ensuring readability in most applications. It is now the simplest way to digitalise a product with RiConnect or any other 3rd party software, engage the user, streamline tasks, and make our working lives much safer and more productive. Along with the other Digital Chips, there is a now a solution for every application.

If you, your inspector, and your customers are seeking to access product information, EC Declarations of Conformity (or Declaration of Conformity or Certificate of Conformance)/Reports of Thorough Examination, User Instructions, Maintenance and Pre-Use check step by step documents, it's as simple as tapping the SupraNano with your mobile device, using the free to user RiConnect APP. What is even more amazing is that the SupraNano can be used with any other 3rd party APP or software, making it one of the most open solutions available today in the Digital Chip/NFC field. SupraNano NFC offers new efficiencies and a safer operating environment.

Just tap the SupraNano and be the first user to experience the power of NFC.

Tech for Safety!

Item No. 13227

SupraNano, Embedded Digital Chip

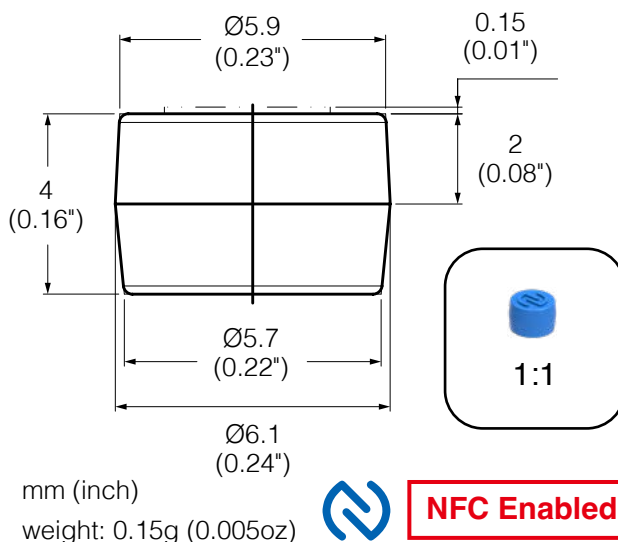

Features:

- Embedded Digital Chip
- NFC enabled mobile device or smart phone (iOS 14 or greater required/ Android 12 or greater required) can be used as reader.
- Patents in several countries.
- By using the Supra Digital Chips with a third-party asset management application to achieve product traceability, manufacturer authentication and digitized product information.

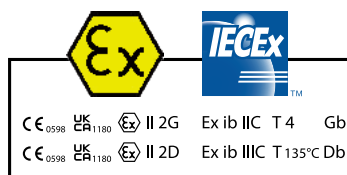

Functionality	
RF Protocol	ISO 15693
Operating Frequency	HF - 13.56 MHz
Memory Configuration	UID 16 bits, User 2K bits
R/W Capability	Read / Write
Performance	
Read Range	Maximum to 5 mm (0.2")
Quality Guarantee	100 %
Orientation	Front Face Read
IP Rating	IP68
Physical	
Materials	PA 6 + 30 GF
Mounting System	Universal Use
Color	Turquoise Blue
Operational	
Max Temperature Exposure	125 °C / 257 °F
Min Temperature Exposure	-30 °C / -22 °F
Continuous Max Service Temperature	125 °C / 257 °F
Continuous Min Service Temperature	-30 °C / -22 °F
Water and Ice Proof	Yes

Patent Number

- » Taiwan Patent: M573545
- » China Patent: ZL 201821589819.6
- » Japan Patent: 3219858
- » United States Patent: 10607128

- » German Patent: 602018032891.2
- » Italy Patent: 3627396
- » UK Patent: 3627396

- » Taiwan Patent: I638765
- » China Patent: ZL 2017 1 0821524.0
- » United States Patent: 10235617



SupraNail, Embedded Digital Chip

SupraNail is an incredible application that utilizes friction principles to securely fit itself to any part of equipment or products, providing an embedded functionality. The structure of SupraNail is forged from stainless steel, showcasing significant aesthetic appeal and robust characteristics. This design allows it to withstand harsh environments, including impacts, oil stains, corrosion, sunlight UV, and other forms of abrasion, thereby ensuring the protection of your digital information.

Through this design, SupraNail not only enhances the flexibility of equipment management but also ensures reliability and durability under various severe conditions, making it a valuable addition to the BlueSupra series.

Item No. 13248
SupraNail, Embedded Digital Chip

NEW

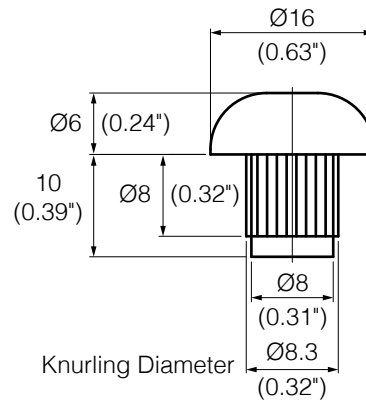

mm (inch)
weight: 10.6g (0.37 oz)



NFC Enabled

Features:

- Embedded Digital Chip
- By using the Supra Digital Chips with a third-party asset management application to achieve product traceability, manufacturer authentication and digitized product information.
- NFC enabled mobile device or smart phone (iOS 14 or greater required/ Android 12 or greater required) can be used as reader.
- Unique design of proprietary wafer-antenna chip construction.

Application:

Engineering Equipment, Machine



Functionality	
RF Protocol	ISO 15693
Operating Frequency	HF - 13.56 MHz
Memory Configuration	UID 16 bits, User 2K bits
R/W Capability	Read / Write
Performance	
Read Range	Maximum to 5 mm (0.2")
Quality Guarantee	100 %
Orientation	Front Face Read
Physical	
Materials	Stainless Steel (Polish)
Mounting System	Universal Use
Operational	
Max Temperature Exposure	125 °C / 257 °F
Min Temperature Exposure	-30 °C / -22 °F
Continuous Max Service Temperature	125 °C / 257 °F
Continuous Min Service Temperature	-30 °C / -22 °F
Water and Ice Proof	Yes



Patent Number

- » Taiwan Patent: M573545
- » China Patent: ZL 201821589819.6
- » Japan Patent: 3219858
- » United States Patent: 10607128

- » German Patent: 602018032891.2
- » Italy Patent: 3627396
- » UK Patent: 3627396

- » Taiwan Patent: 1638765
- » China Patent: ZL 2017 1 0821524.0
- » United States Patent: 10235617

- » United States Patent: 11305844
- » Japan Patent: 3220091

Installation Instruction

Option A

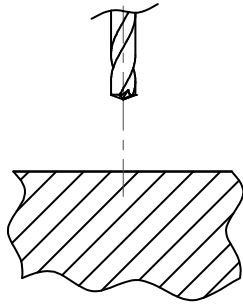

① Prepare tool

Option B

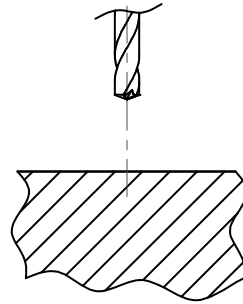

① Prepare tool

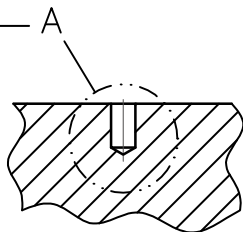

② Drill the hole

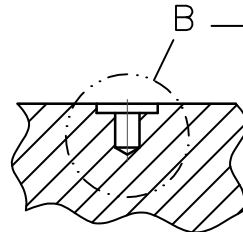

② Drill the hole

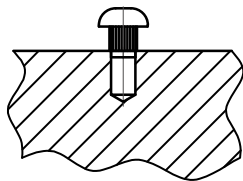

③ Put the rivet

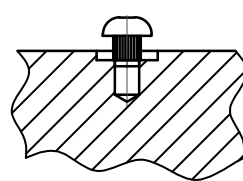

③ Put the rivet

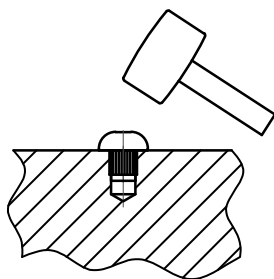

④ Set the rivet

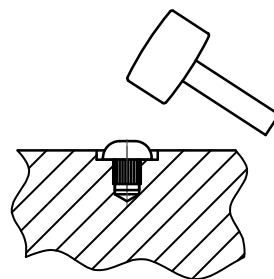

④ Set the rivet

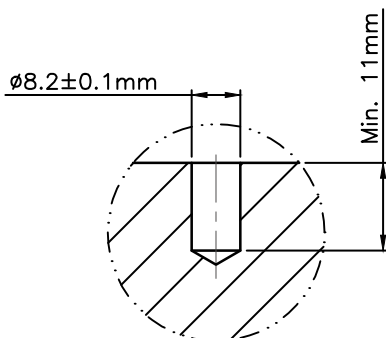

DETAIL A

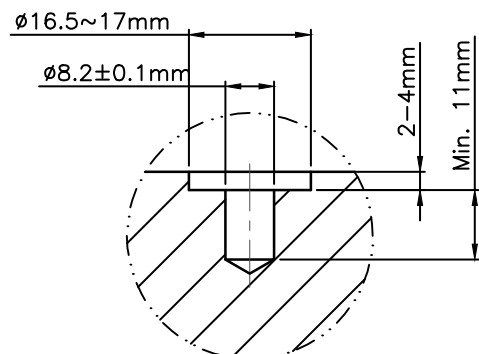

DETAIL B

BlueSupra Series, Robust Digital Chips

The use of plastic Digital Chips in a severe offshore working environment can lead to the loss or corruption of data, especially when the plastic chip is subject to continuous impact damage, UV from sunlight, corrosion, oil pollution and other mechanical damage experienced when working in challenging conditions.

The application of the BlueSupra Series can avoid this risk.



Unlike conventional plastic chips prone to damage from environmental factors, the BlueSupra Series offers unmatched resilience. Crafted from robust materials and engineered to surpass industry standards, these chips ensure reliable performance in demanding conditions. With advanced protection against dust, water, and impact, the BlueSupra Series is the optimal choice for safeguarding data integrity and operational continuity.



- Meet the requirement of US Military Standard MIL-STD-810H.



- The product is made of corrosion-resistant stainless steel, aluminum, or bronze.



- Meet Highest IP68 rating of dust and water resistance.



- Meet IK10 impact protection level.

Item No. 13243
SupraTag



[SUS304]

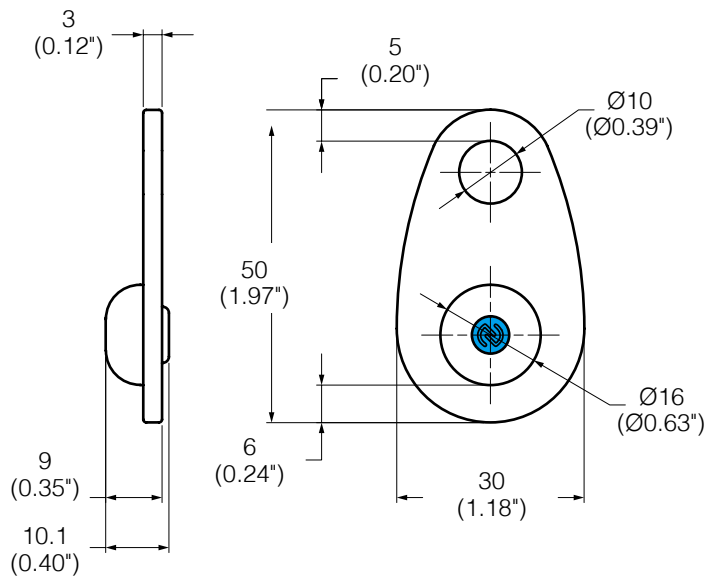

mm (inch)
 weight: 33g (1.16oz)



NFC Enabled

Features:

- By using the Supra Digital Chips with a third-party asset management application to achieve product traceability, manufacturer authentication and digitized product information.
- NFC enabled mobile device or smart phone (iOS 14 or greater required/ Android 12 or greater required) can be used as reader.
- Unique design of proprietary wafer-antenna chip construction.

Application:

Universal

Functionality	
RF Protocol	ISO 15693
Operating Frequency	HF - 13.56 MHz
Memory Configuration	UID 16 bits, User 2K bits
R/W Capability	Read / Write
Performance	
Read Range	Maximum to 5 mm [0.2"]
Quality Guarantee	100 %
Orientation	Front Face Read
Physical	
Materials	Stainless Steel (Polish)
Mounting System	Universal Use
Operational	
Max Temperature Exposure	125 °C / 257 °F
Min Temperature Exposure	-30 °C / -22 °F
Continuous Max Service Temperature	125 °C / 257 °F
Continuous Min Service Temperature	-30 °C / -22 °F
Water and Ice Proof	Yes



Patent Number

- » Taiwan Patent: M573545
- » China Patent: ZL 201821589819.6
- » Japan Patent: 3219858
- » United States Patent: 10607128
- » German Patent: 602018032891.2
- » Italy Patent: 3627396
- » UK Patent: 3627396
- » Taiwan Patent: 1638765
- » China Patent: ZL 2017 1 0821524.0
- » United States Patent: 10235617
- » United States Patent: 11305844
- » Japan Patent: 3220091

No other digital product goes deeper!

Many try to overcome the challenges of working at depths of upto 6,000 metres, now the SupraTag can meet this demand. Moments after submersion of the ROV Hook, ROV Shackle or SupraTag can be scanned and read in a single click for pre use and post use operations, safe use instructions and asset management. Ensuring there is no higher safety available to the operator, reducing downtime which is vital to the ROV pilot.



Item No. 13282 SupraLoop

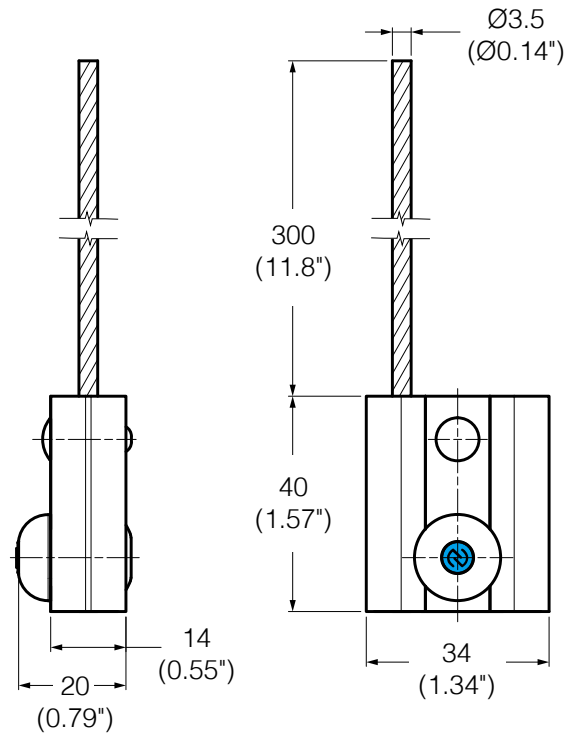

mm (inch)
weight: 47g (1.66oz)



NFC Enabled

Features:

- The 7x19 stainless steel wire rope with a diameter of 3.5mm is strong, flexible, and convenient to use. The tensile strength of the wire rope is greater than 10kN.
- By using the Supra Digital Chips with a third-party asset management application to achieve product traceability, manufacturer authentication and digitized product information.
- NFC enabled mobile device or smart phone (iOS 14 or greater required/ Android 12 or greater required) can be used as reader.
- Unique design of proprietary wafer-antenna chip construction.

Application:

Universal

Functionality	
RF Protocol	ISO 15693
Operating Frequency	HF - 13.56 MHz
Memory Configuration	UID 16 bits, User 2K bits
R/W Capability	Read / Write
Performance	
Read Range	Maximum to 5 mm (0.2")
Quality Guarantee	100 %
Orientation	Front Face Read
Physical	
Materials	Stainless Steel (Polish)
Mounting System	Universal Use
Operational	
Max Temperature Exposure	125 °C / 257 °F
Min Temperature Exposure	-30 °C / -22 °F
Continuous Max Service Temperature	125 °C / 257 °F
Continuous Min Service Temperature	-30 °C / -22 °F
Water and Ice Proof	Yes



Patent Number

» Taiwan Patent: M573545
 » China Patent: ZL 201821589819.6
 » Japan Patent: 3219858
 » United States Patent: 10607128

» German Patent: 602018032891.2
 » Italy Patent: 3627396
 » UK Patent: 3627396

» Taiwan Patent: 1638765
 » China Patent: ZL 2017 1 0821524.0
 » United States Patent: 10235617

» United States Patent: 11305844
 » Japan Patent: 3220091



Item No. 13271

Supra HoseTag, 7mm

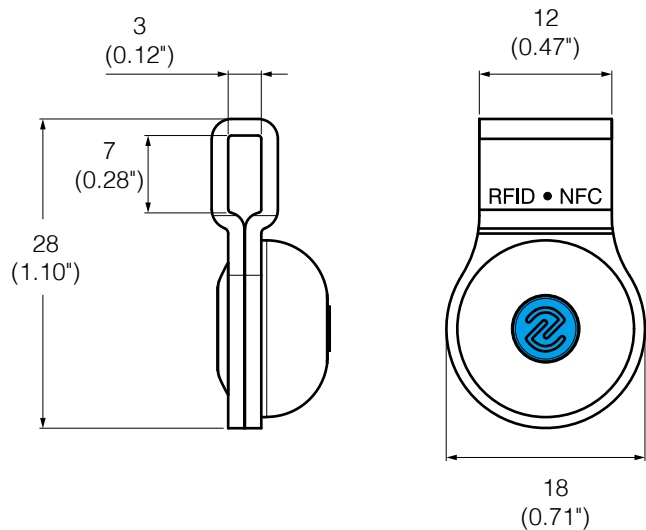

mm (inch)
weight: 17.5g (0.62 oz)



NFC Enabled

Features:

- By using the Supra Digital Chips with a third-party asset management application to achieve product traceability, manufacturer authentication and digitized product information.
- NFC enabled mobile device or smart phone (iOS 14 or greater required/ Android 12 or greater required) can be used as reader.
- Unique design of proprietary wafer-antenna chip construction.

Application:

Pipeline, Hose, Valve

Functionality	
RF Protocol	ISO 15693
Operating Frequency	HF - 13.56 MHz
Memory Configuration	UID 16 bits, User 2K bits
R/W Capability	Read / Write
Performance	
Read Range	Maximum to 5 mm [0.2"]
Quality Guarantee	100 %
Orientation	Front Face Read
Physical	
Materials	Stainless Steel (Polish)
Mounting System	Universal Use
Operational	
Max Temperature Exposure	125 °C / 257 °F
Min Temperature Exposure	-30 °C / -22 °F
Continuous Max Service Temperature	125 °C / 257 °F
Continuous Min Service Temperature	-30 °C / -22 °F
Water and Ice Proof	Yes



Patent Number

- » Taiwan Patent: M573545
- » China Patent: ZL 201821589819.6
- » Japan Patent: 3219858
- » United States Patent: 10607128

- » German Patent: 602018032891.2
- » Italy Patent: 3627396
- » UK Patent: 3627396

- » Taiwan Patent: 1638765
- » China Patent: ZL 2017 1 0821524.0
- » United States Patent: 10235617

- » United States Patent: 11305844
- » Japan Patent: 3220091

Item No. 13273
Supra HoseTag, 16mm

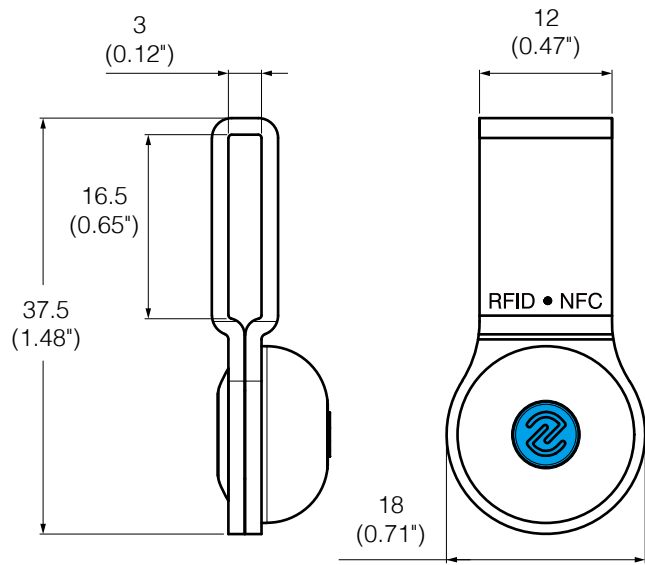

mm (inch)
 weight: 17.5g (0.62 oz)



NFC Enabled

Features:

- By using the Supra Digital Chips with a third-party asset management application to achieve product traceability, manufacturer authentication and digitized product information.
- NFC enabled mobile device or smart phone (iOS 14 or greater required/ Android 12 or greater required) can be used as reader.
- Unique design of proprietary wafer-antenna chip construction.

Application:

Pipeline, Hose, Valve, Wire Rope Sling

Functionality	
RF Protocol	ISO 15693
Operating Frequency	HF - 13.56 MHz
Memory Configuration	UID 16 bits, User 2K bits
R/W Capability	Read / Write
Performance	
Read Range	Maximum to 5 mm [0.2"]
Quality Guarantee	100 %
Orientation	Front Face Read
Physical	
Materials	Stainless Steel (Polish)
Mounting System	Universal Use
Operational	
Max Temperature Exposure	125 °C / 257 °F
Min Temperature Exposure	-30 °C / -22 °F
Continuous Max Service Temperature	125 °C / 257 °F
Continuous Min Service Temperature	-30 °C / -22 °F
Water and Ice Proof	Yes



Patent Number

- » Taiwan Patent: M573545
- » China Patent: ZL 201821589819.6
- » Japan Patent: 3219858
- » United States Patent: 10607128

- » German Patent: 602018032891.2
- » Italy Patent: 3627396
- » UK Patent: 3627396

- » Taiwan Patent: 1638765
- » China Patent: ZL 2017 1 0821524.0
- » United States Patent: 10235617

- » United States Patent: 11305844
- » Japan Patent: 3220091

Item No. 13279 SupraRing

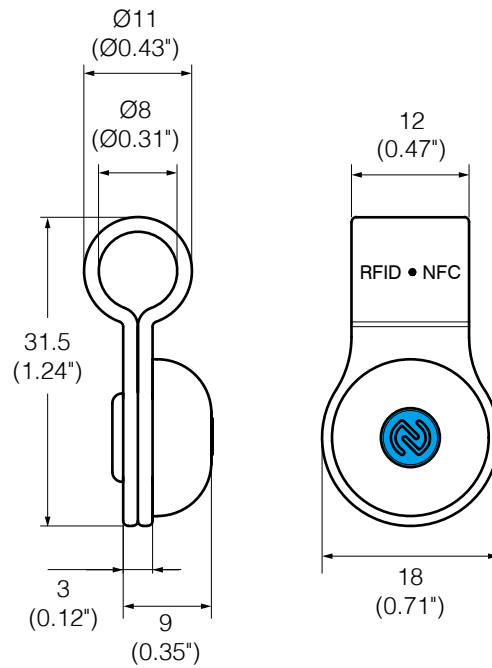

mm (inch)
weight: 18g (0.63oz)



NFC Enabled

Features:

- By using the Supra Digital Chips with a third-party asset management application to achieve product traceability, manufacturer authentication and digitized product information.
- NFC enabled mobile device or smart phone (iOS 14 or greater required/ Android 12 or greater required) can be used as reader.
- Unique design of proprietary wafer-antenna chip construction.

Application:

Pipeline, Hose, Valve

Functionality	
RF Protocol	ISO 15693
Operating Frequency	HF - 13.56 MHz
Memory Configuration	UID 16 bits, User 2K bits
R/W Capability	Read / Write
Performance	
Read Range	Maximum to 5 mm [0.2"]
Quality Guarantee	100 %
Orientation	Front Face Read
Physical	
Materials	Stainless Steel (Polish)
Mounting System	Universal Use
Operational	
Max Temperature Exposure	125 °C / 257 °F
Min Temperature Exposure	-30 °C / -22 °F
Continuous Max Service Temperature	125 °C / 257 °F
Continuous Min Service Temperature	-30 °C / -22 °F
Water and Ice Proof	Yes



Patent Number

- » Taiwan Patent: M573545
- » China Patent: ZL 201821589819.6
- » Japan Patent: 3219858
- » United States Patent: 10607128

- » German Patent: 602018032891.2
- » Italy Patent: 3627396
- » UK Patent: 3627396

- » Taiwan Patent: 1638765
- » China Patent: ZL 2017 1 0821524.0
- » United States Patent: 10235617

- » United States Patent: 11305844
- » Japan Patent: 3220091

Item No. 13272
SupraMini

NEW

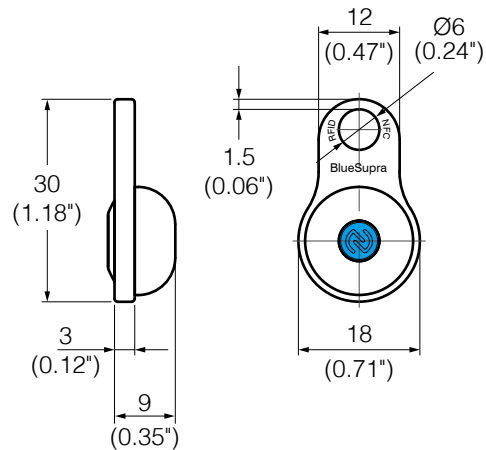
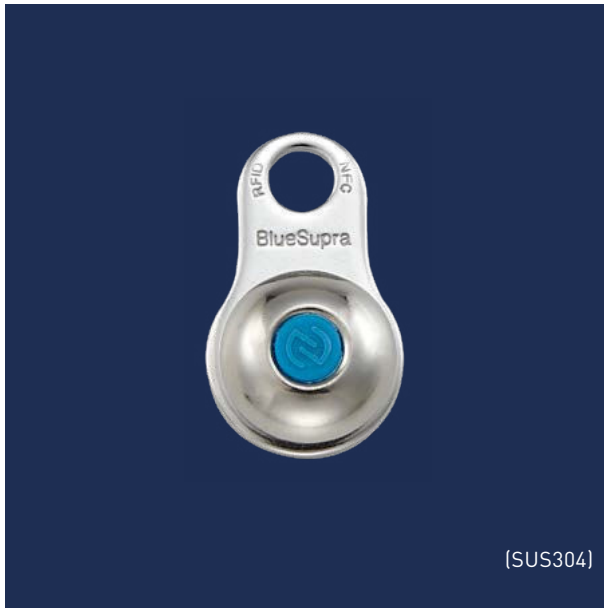

mm (inch)
weight: 16g (0.56oz)



NFC Enabled

Features:

- By using the Supra Digital Chips with a third-party asset management application to achieve product traceability, manufacturer authentication and digitized product information.
- NFC enabled mobile device or smart phone (iOS 14 or greater required/ Android 12 or greater required) can be used as reader.
- Unique design of proprietary wafer-antenna chip construction.

Application:

Universal

Functionality	
RF Protocol	ISO 15693
Operating Frequency	HF - 13.56 MHz
Memory Configuration	UID 16 bits, User 2K bits
R/W Capability	Read / Write
Performance	
Read Range	Maximum to 5 mm [0.2"]
Quality Guarantee	100 %
Orientation	Front Face Read
Physical	
Materials	Stainless Steel (Polish)
Mounting System	Universal Use
Operational	
Max Temperature Exposure	125 °C / 257 °F
Min Temperature Exposure	-30 °C / -22 °F
Continuous Max Service Temperature	125 °C / 257 °F
Continuous Min Service Temperature	-30 °C / -22 °F
Water and Ice Proof	Yes



Patent Number

- » Taiwan Patent: M573545
- » China Patent: ZL 201821589819.6
- » Japan Patent: 3219858
- » United States Patent: 10607128
- » German Patent: 602018032891.2
- » Italy Patent: 3627396
- » UK Patent: 3627396
- » Taiwan Patent: 1638765
- » China Patent: ZL 2017 1 0821524.0
- » United States Patent: 10235617
- » United States Patent: 11305844
- » Japan Patent: 3220091

Item No. 13226
SupraBolt, M8x20mm

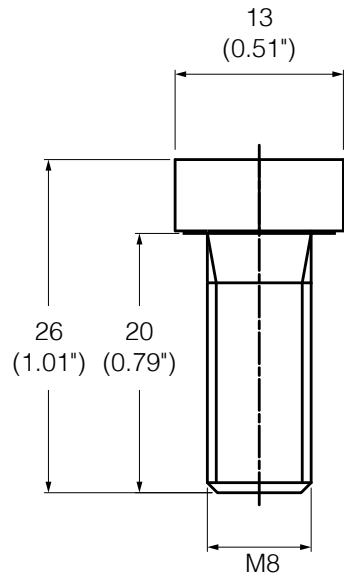

mm (inch)
 weight: 10.6g (0.37oz)



NFC Enabled

Features:

- Metric Thread
- By using the Supra Digital Chips with a third-party asset management application to achieve product traceability, manufacturer authentication and digitized product information.
- NFC enabled mobile device or smart phone (iOS 14 or greater required/ Android 12 or greater required) can be used as reader.
- Unique design of proprietary wafer-antenna chip construction.

Application:

Engineering Equipment, Machine

Functionality	
RF Protocol	ISO 15693
Operating Frequency	HF - 13.56 MHz
Memory Configuration	UID 16 bits, User 2K bits
R/W Capability	Read / Write
Performance	
Read Range	Maximum to 5 mm [0.2"]
Quality Guarantee	100 %
Orientation	Front Face Read
Physical	
Materials	Stainless Steel (Polish)
Mounting System	Universal Use
Operational	
Max Temperature Exposure	125 °C / 257 °F
Min Temperature Exposure	-30 °C / -22 °F
Continuous Max Service Temperature	125 °C / 257 °F
Continuous Min Service Temperature	-30 °C / -22 °F
Water and Ice Proof	Yes



Patent Number

- » Taiwan Patent: M573545
- » China Patent: ZL 201821589819.6
- » Japan Patent: 3219858
- » United States Patent: 10607128
- » German Patent: 602018032891.2
- » Italy Patent: 3627396
- » UK Patent: 3627396
- » Taiwan Patent: 1638765
- » China Patent: ZL 2017 1 0821524.0
- » United States Patent: 10235617
- » United States Patent: 11305844
- » Japan Patent: 3220091

Item No. 13228
SupraBolt, 5/16x3/4"

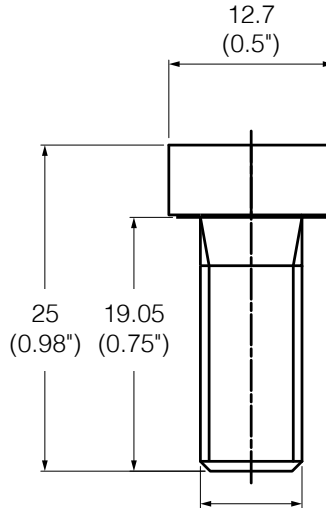

5/16 - 18UNC
 mm (inch)
 weight: 10.4g (0.36oz)



NFC Enabled

Features:

- UNC Thread
- By using the Supra Digital Chips with a third-party asset management application to achieve product traceability, manufacturer authentication and digitized product information.
- NFC enabled mobile device or smart phone (iOS 14 or greater required/ Android 12 or greater required) can be used as reader.
- Unique design of proprietary wafer-antenna chip construction.

Application:

Engineering Equipment, Machine

Functionality	
RF Protocol	ISO 15693
Operating Frequency	HF - 13.56 MHz
Memory Configuration	UID 16 bits, User 2K bits
R/W Capability	Read / Write
Performance	
Read Range	Maximum to 5 mm [0.2"]
Quality Guarantee	100 %
Orientation	Front Face Read
Physical	
Materials	Stainless Steel (Polish)
Mounting System	Universal Use
Operational	
Max Temperature Exposure	125 °C / 257 °F
Min Temperature Exposure	-30 °C / -22 °F
Continuous Max Service Temperature	125 °C / 257 °F
Continuous Min Service Temperature	-30 °C / -22 °F
Water and Ice Proof	Yes



Patent Number

- » Taiwan Patent: M573545
- » China Patent: ZL 201821589819.6
- » Japan Patent: 3219858
- » United States Patent: 10607128
- » German Patent: 602018032891.2
- » Italy Patent: 3627396
- » UK Patent: 3627396
- » Taiwan Patent: 1638765
- » China Patent: ZL 2017 1 0821524.0
- » United States Patent: 10235617
- » United States Patent: 11305844
- » Japan Patent: 3220091

Item No. 13221

SupraCastle, M10x20mm

NEW

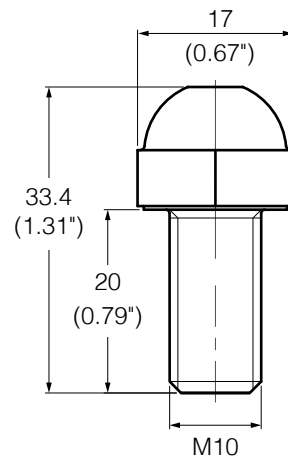

mm (inch)
weight: 16g (0.56oz)



NFC Enabled

Features:

- Metric Thread
- By using the Supra Digital Chips with a third-party asset management application to achieve product traceability, manufacturer authentication and digitized product information.
- NFC enabled mobile device or smart phone (iOS 14 or greater required/ Android 12 or greater required) can be used as reader.
- Unique design of proprietary wafer-antenna chip construction.

Application:

Engineering Equipment, Machine

Functionality	
RF Protocol	ISO 15693
Operating Frequency	HF - 13.56 MHz
Memory Configuration	UID 16 bits, User 2K bits
R/W Capability	Read / Write
Performance	
Read Range	Maximum to 5 mm [0.2"]
Quality Guarantee	100 %
Orientation	Front Face Read
Physical	
Materials	Stainless Steel (Polish)
Mounting System	Universal Use
Operational	
Max Temperature Exposure	125 °C / 257 °F
Min Temperature Exposure	-30 °C / -22 °F
Continuous Max Service Temperature	125 °C / 257 °F
Continuous Min Service Temperature	-30 °C / -22 °F
Water and Ice Proof	Yes



Patent Number

- » Taiwan Patent: M573545
- » China Patent: ZL 201821589819.6
- » Japan Patent: 3219858
- » United States Patent: 10607128

- » German Patent: 602018032891.2
- » Italy Patent: 3627396
- » UK Patent: 3627396

- » Taiwan Patent: 1638765
- » China Patent: ZL 2017 1 0821524.0
- » United States Patent: 10235617

- » United States Patent: 11305844
- » Japan Patent: 3220091

Item No. 13223

SupraCastle, 3/8x3/4"

NEW



[SUS304]

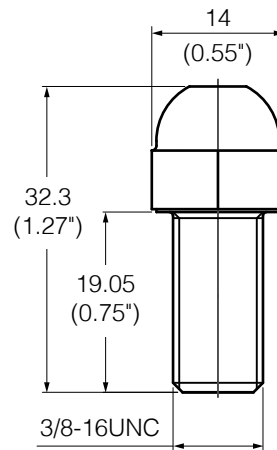

mm (inch)

weight: 16g (0.56oz)



NFC Enabled

Features:

- UNC Thread
- By using the Supra Digital Chips with a third-party asset management application to achieve product traceability, manufacturer authentication and digitized product information.
- NFC enabled mobile device or smart phone (iOS 14 or greater required/ Android 12 or greater required) can be used as reader.
- Unique design of proprietary wafer-antenna chip construction.

Application:

Engineering Equipment, Machine

Functionality	
RF Protocol	ISO 15693
Operating Frequency	HF - 13.56 MHz
Memory Configuration	UID 16 bits, User 2K bits
R/W Capability	Read / Write
Performance	
Read Range	Maximum to 5 mm [0.2"]
Quality Guarantee	100 %
Orientation	Front Face Read
Physical	
Materials	Stainless Steel (Polish)
Mounting System	Universal Use
Operational	
Max Temperature Exposure	125 °C / 257 °F
Min Temperature Exposure	-30 °C / -22 °F
Continuous Max Service Temperature	125 °C / 257 °F
Continuous Min Service Temperature	-30 °C / -22 °F
Water and Ice Proof	Yes



Patent Number

- » Taiwan Patent: M573545
- » China Patent: ZL 201821589819.6
- » Japan Patent: 3219858
- » United States Patent: 10607128

- » German Patent: 602018032891.2
- » Italy Patent: 3627396
- » UK Patent: 3627396

- » Taiwan Patent: 1638765
- » China Patent: ZL 2017 1 0821524.0
- » United States Patent: 10235617

- » United States Patent: 11305844
- » Japan Patent: 3220091

SupraPlate

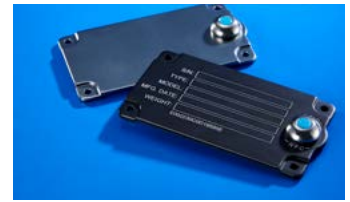

Digital nameplates represent a transformative solution that addresses regulatory compliance and enhances management through IoT technology in both the United States and the European Union.

In the EU, directives like the Machinery Directive and Work Equipment Directive mandate clear equipment labeling and safety signage. Digital nameplates streamline compliance by digitally displaying essential information such as manufacturer details, model numbers, and CE markings, ensuring visibility and clarity that meet EU standards.

Similarly, in the US, OSHA regulations require effective safety signage and hazard communication. Digital nameplates not only meet these requirements but also enable real-time updates and remote monitoring via IoT connectivity. This ensures that safety information remains current and accessible, enhancing workplace safety and compliance.

By leveraging IoT technology, digital nameplates offer benefits beyond traditional static labels. They provide dynamic management capabilities, enabling proactive maintenance alerts, remote diagnostics, and compliance monitoring. This digital approach not only simplifies regulatory adherence but also improves operational efficiency and safety across both US and EU jurisdictions.

In conclusion, digital nameplates represent a pivotal advancement in regulatory compliance and management, aligning seamlessly with both US and EU standards while harnessing the power of IoT for enhanced safety and operational oversight.

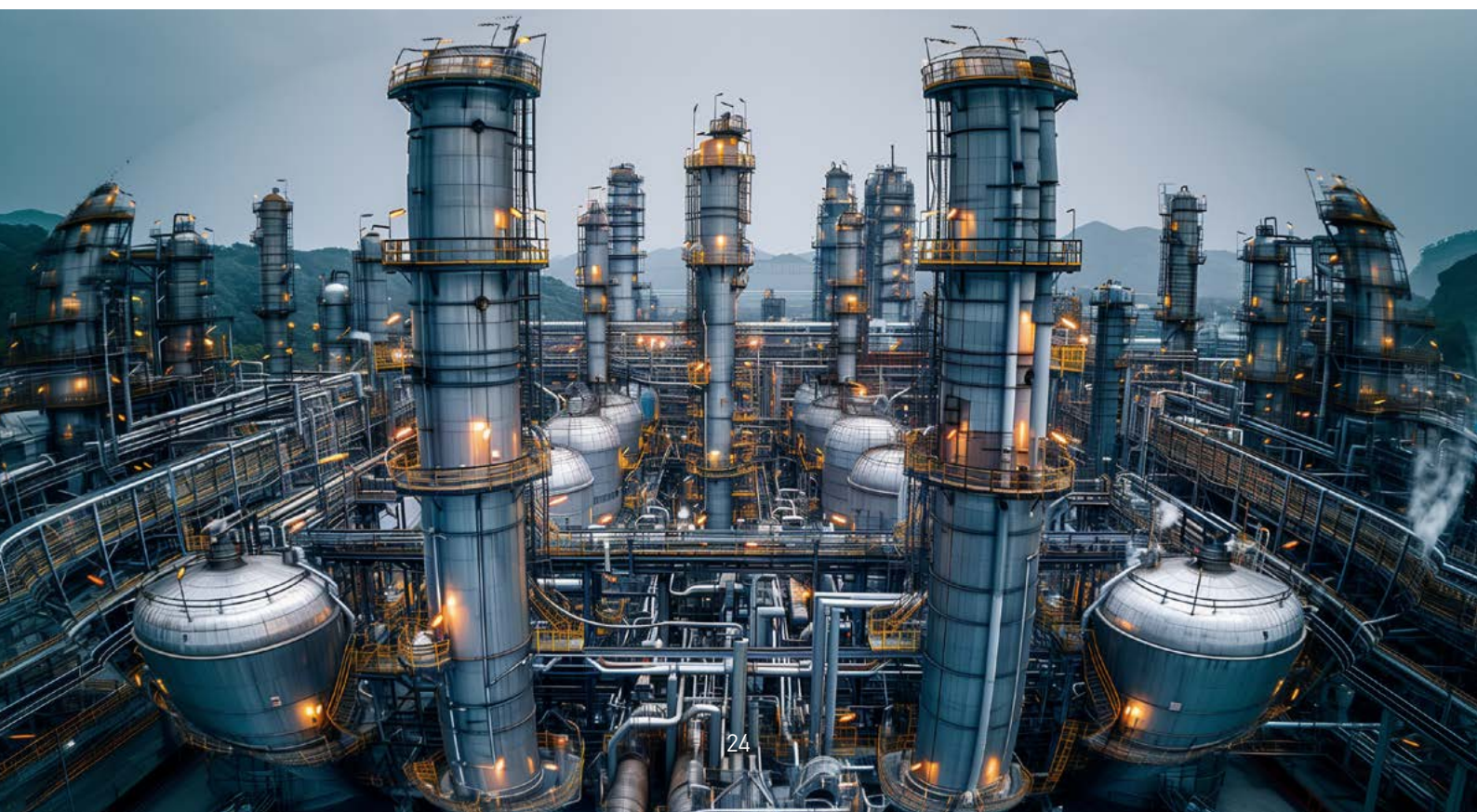



Item No. 13263

SupraPlate, Nameplate.

NEW



[Aluminum]

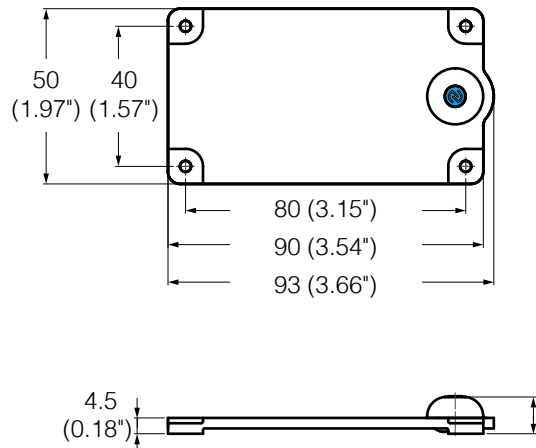

mm (inch)
weight: 44g (1.55oz)



NFC Enabled

Features:

- By using the Supra Digital Chips with a third-party asset management application to achieve product traceability, manufacturer authentication and digitized product information.
- NFC enabled mobile device or smart phone (iOS 14 or greater required/ Android 12 or greater required) can be used as reader.
- Unique design of proprietary wafer-antenna chip construction.

Application:

Engineering Equipment, Machine



Functionality	
RF Protocol	ISO 15693
Operating Frequency	HF - 13.56 MHz
Memory Configuration	UID 16 bits, User 2K bits
R/W Capability	Read / Write
Performance	
Read Range	Maximum to 5 mm [0.2"]
Quality Guarantee	100 %
Orientation	Front Face Read
Physical	
Materials	Aluminum (Anodizing)
Mounting System	Universal Use
Operational	
Max Temperature Exposure	125 °C / 257 °F
Min Temperature Exposure	-30 °C / -22 °F
Continuous Max Service Temperature	125 °C / 257 °F
Continuous Min Service Temperature	-30 °C / -22 °F
Water and Ice Proof	Yes



Patent Number

- » Taiwan Patent: M573545
- » China Patent: ZL 201821589819.6
- » Japan Patent: 3219858
- » United States Patent: 10607128
- » German Patent: 602018032891.2
- » Italy Patent: 3627396
- » UK Patent: 3627396
- » Taiwan Patent: 1638765
- » China Patent: ZL 2017 1 0821524.0
- » United States Patent: 10235617
- » United States Patent: 11305844
- » Japan Patent: 3220091



Digital sling tag

Introducing the Digital Sling Tag - your ultimate solution to meet strict lifting equipment regulations such as LOLER, PUWER, HSE, OSHA, and ASME B30. This innovative tag ensures full compliance while leveraging IoT technology to revolutionize your documentation management.

No more paper and pen for inspection records. The Digital Sling Tag integrates seamlessly with your digital platform, providing real-time data and automated updates. It captures vital information like load capacity and inspection dates, making compliance effortless.

By digitizing your records, the Digital Sling Tag dramatically boosts efficiency. It automates inspection cycles, minimizes downtime, and enhances safety protocols. Embrace the future of digital documentation and compliance management with the Digital Sling Tag, and transform the way you operate.



Item No. 13236
SupraWeb, Web Sling Tag

NEW

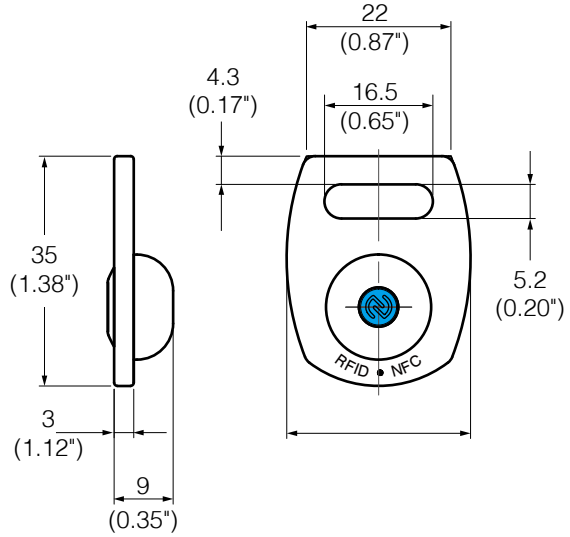

mm (inch)
 weight: 16g (0.56oz)



Features:

- By using the Supra Digital Chips with a third-party asset management application to achieve product traceability, manufacturer authentication and digitized product information.
- NFC enabled mobile device or smart phone (iOS 14 or greater required/ Android 12 or greater required) can be used as reader.
- Unique design of proprietary wafer-antenna chip construction.

Application:

Lifting Sling

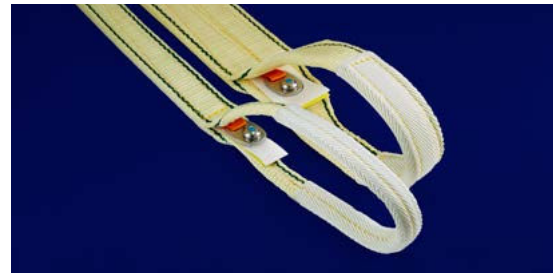

Functionality	
RF Protocol	ISO 15693
Operating Frequency	HF - 13.56 MHz
Memory Configuration	UID 16 bits, User 2K bits
R/W Capability	Read / Write
Performance	
Read Range	Maximum to 5 mm [0.2"]
Quality Guarantee	100 %
Orientation	Front Face Read
Physical	
Materials	Stainless Steel (Polish)
Mounting System	Universal Use
Operational	
Max Temperature Exposure	125 °C / 257 °F
Min Temperature Exposure	-30 °C / -22 °F
Continuous Max Service Temperature	125 °C / 257 °F
Continuous Min Service Temperature	-30 °C / -22 °F
Water and Ice Proof	Yes



Patent Number

- » Taiwan Patent: M573545
- » China Patent: ZL 201821589819.6
- » Japan Patent: 3219858
- » United States Patent: 10607128
- » German Patent: 602018032891.2
- » Italy Patent: 3627396
- » UK Patent: 3627396
- » Taiwan Patent: 1638765
- » China Patent: ZL 2017 1 0821524.0
- » United States Patent: 10235617
- » United States Patent: 11305844
- » Japan Patent: 3220091

Item No. 13286 SupraButtom, Web Sling Tag

NEW

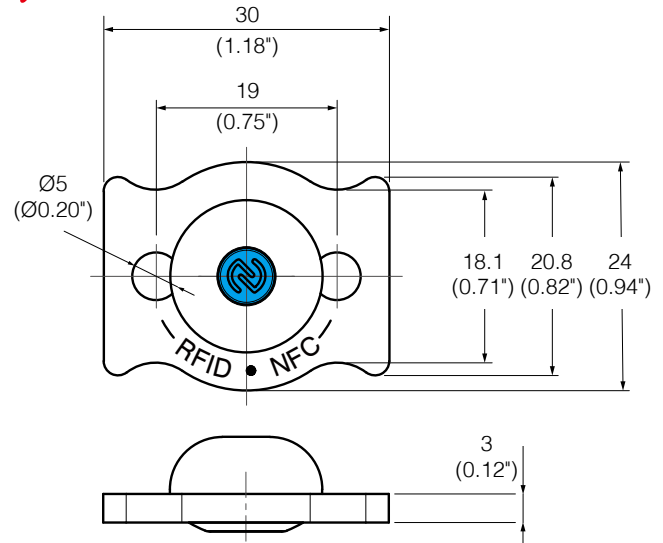

mm (inch)
weight: 21 g (0.74 oz.)



NFC Enabled

Features:

- By using the Supra Digital Chips with a third-party asset management application to achieve product traceability, manufacturer authentication and digitized product information.
- NFC enabled mobile device or smart phone (iOS 14 or greater required/ Android 12 or greater required) can be used as reader.
- Unique design of proprietary wafer-antenna chip construction.

Application:

Universal



Functionality	
RF Protocol	ISO 15693
Operating Frequency	HF - 13.56 MHz
Memory Configuration	UID 16 bits, User 2K bits
R/W Capability	Read / Write
Performance	
Read Range	Maximum to 5 mm (0.2")
Quality Guarantee	100 %
Orientation	Front Face Read
Physical	
Materials	Stainless Steel (Polish)
Mounting System	Universal Use
Operational	
Max Temperature Exposure	125 °C / 257 °F
Min Temperature Exposure	-30 °C / -22 °F
Continuous Max Service Temperature	125 °C / 257 °F
Continuous Min Service Temperature	-30 °C / -22 °F
Water and Ice Proof	Yes



Patent Number

- » Taiwan Patent: M573545
- » China Patent: ZL 201821589819.6
- » Japan Patent: 3219858
- » United States Patent: 10607128

- » German Patent: 602018032891.2
- » Italy Patent: 3627396
- » UK Patent: 3627396

- » Taiwan Patent: 1638765
- » China Patent: ZL 2017 1 0821524.0
- » United States Patent: 10235617

- » United States Patent: 11305844
- » Japan Patent: 3220091

Item No. 13287

SupraWireTag, Wire Rope Sling Tag

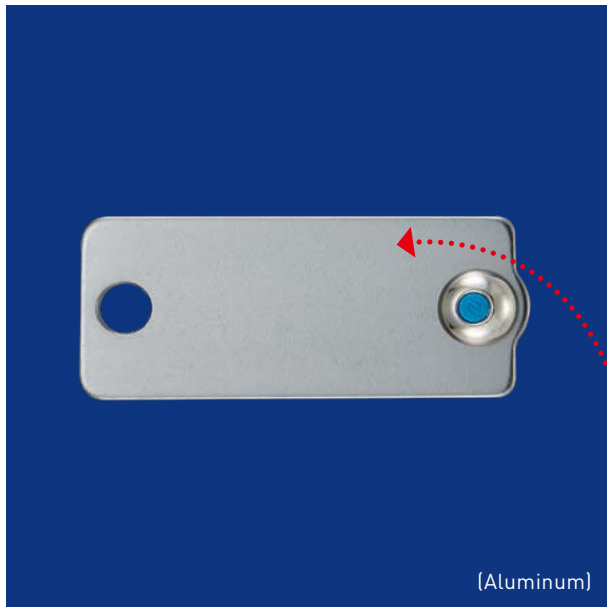

[Aluminum]

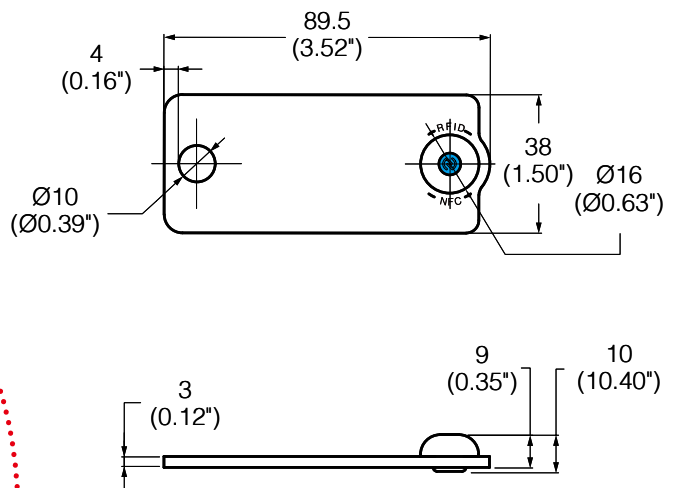

mm (inch)
weight: 33g (1.16oz)



NFC Enabled

Custom Logo, Custom Content

Features:

- By using the Supra Digital Chips with a third-party asset management application to achieve product traceability, manufacturer authentication and digitized product information.
- NFC enabled mobile device or smart phone (iOS 14 or greater required/ Android 12 or greater required) can be used as reader.
- Unique design of proprietary wafer-antenna chip construction.

Application:

Lifting Sling

Functionality	
RF Protocol	ISO 15693
Operating Frequency	HF - 13.56 MHz
Memory Configuration	UID 16 bits, User 2K bits
R/W Capability	Read / Write
Performance	
Read Range	Maximum to 5 mm [0.2"]
Quality Guarantee	100 %
Orientation	Front Face Read
Physical	
Materials	Aluminum [Anodizing]
Mounting System	Universal Use
Operational	
Max Temperature Exposure	125 °C / 257 °F
Min Temperature Exposure	-30 °C / -22 °F
Continuous Max Service Temperature	125 °C / 257 °F
Continuous Min Service Temperature	-30 °C / -22 °F
Water and Ice Proof	Yes



Patent Number

- » Taiwan Patent: M573545
- » China Patent: ZL 201821589819.6
- » Japan Patent: 3219858
- » United States Patent: 10607128

- » German Patent: 602018032891.2
- » Italy Patent: 3627396
- » UK Patent: 3627396

- » Taiwan Patent: 1638765
- » China Patent: ZL 2017 1 0821524.0
- » United States Patent: 10235617

- » United States Patent: 11305844
- » Japan Patent: 3220091



Item No. 13281

Supra ChainTag, Chain sling Tag.

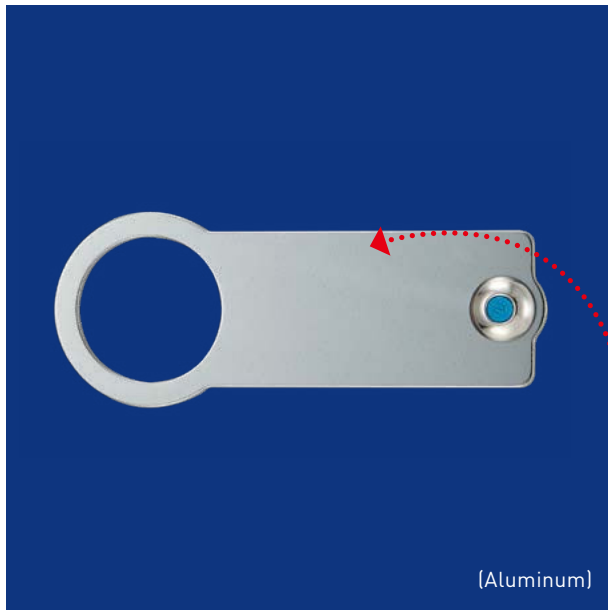

[Aluminum]

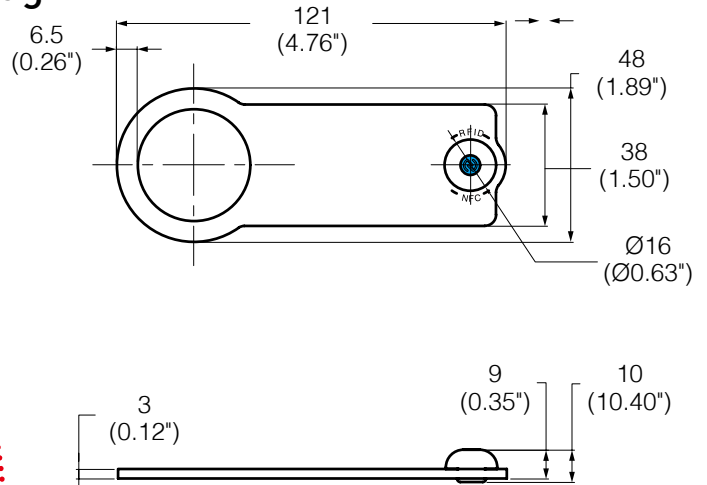

mm (inch)
weight: 36.2g (1.28oz)



NFC Enabled

Custom Logo, Custom Content

Features:

- By using the Supra Digital Chips with a third-party asset management application to achieve product traceability, manufacturer authentication and digitized product information.
- NFC enabled mobile device or smart phone (iOS 14 or greater required/ Android 12 or greater required) can be used as reader.
- Unique design of proprietary wafer-antenna chip construction.

Application:

Lifting Chain Sling

Functionality	
RF Protocol	ISO 15693
Operating Frequency	HF - 13.56 MHz
Memory Configuration	UID 16 bits, User 2K bits
R/W Capability	Read / Write
Performance	
Read Range	Maximum to 5 mm [0.2"]
Quality Guarantee	100 %
Orientation	Front Face Read
Physical	
Materials	Aluminum [Anodizing]
Mounting System	Universal Use
Operational	
Max Temperature Exposure	125 °C / 257 °F
Min Temperature Exposure	-30 °C / -22 °F
Continuous Max Service Temperature	125 °C / 257 °F
Continuous Min Service Temperature	-30 °C / -22 °F
Water and Ice Proof	Yes



Patent Number

- » Taiwan Patent: M573545
- » China Patent: ZL 201821589819.6
- » Japan Patent: 3219858
- » United States Patent: 10607128

- » German Patent: 602018032891.2
- » Italy Patent: 3627396
- » UK Patent: 3627396

- » Taiwan Patent: 1638765
- » China Patent: ZL 2017 1 0821524.0
- » United States Patent: 10235617

- » United States Patent: 11305844
- » Japan Patent: 3220091

Item No. 13285

Supra ChainTag, G80 Chain sling Tag



[Aluminum]

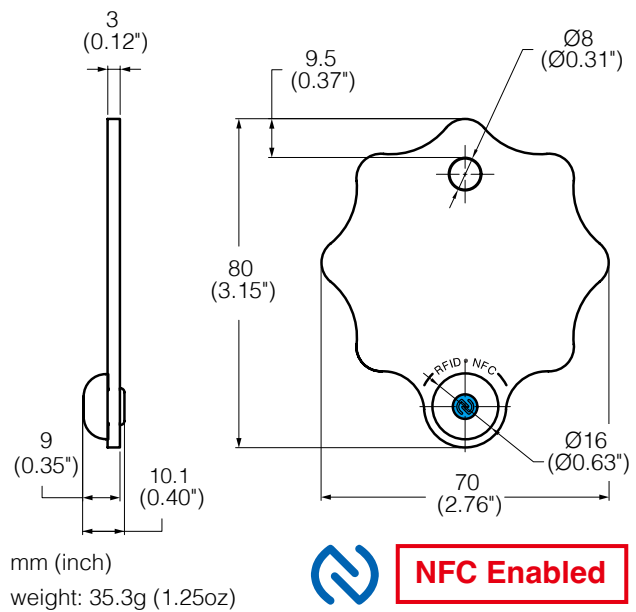

mm (inch)
weight: 35.3g (1.25oz)



NFC Enabled

Custom Logo, Custom Content

Features:

- By using the Supra Digital Chips with a third-party asset management application to achieve product traceability, manufacturer authentication and digitized product information.
- NFC enabled mobile device or smart phone (iOS 14 or greater required/ Android 12 or greater required) can be used as reader.
- Unique design of proprietary wafer-antenna chip construction.

Application:

Lifting Chain Sling

Functionality	
RF Protocol	ISO 15693
Operating Frequency	HF - 13.56 MHz
Memory Configuration	UID 16 bits, User 2K bits
R/W Capability	Read / Write
Performance	
Read Range	Maximum to 5 mm [0.2"]
Quality Guarantee	100 %
Orientation	Front Face Read
Physical	
Materials	Aluminum (Anodizing)
Mounting System	Universal Use
Operational	
Max Temperature Exposure	125 °C / 257 °F
Min Temperature Exposure	-30 °C / -22 °F
Continuous Max Service Temperature	125 °C / 257 °F
Continuous Min Service Temperature	-30 °C / -22 °F
Water and Ice Proof	Yes



Patent Number

- » Taiwan Patent: M573545
- » China Patent: ZL 201821589819.6
- » Japan Patent: 3219858
- » United States Patent: 10607128
- » German Patent: 602018032891.2
- » Italy Patent: 3627396
- » UK Patent: 3627396
- » Taiwan Patent: 1638765
- » China Patent: ZL 2017 1 0821524.0
- » United States Patent: 10235617
- » United States Patent: 11305844
- » Japan Patent: 3220091

Item No. 13288

Supra ChainTag, G100 Chain sling Tag



[Aluminum]

Custom Logo, Custom Content

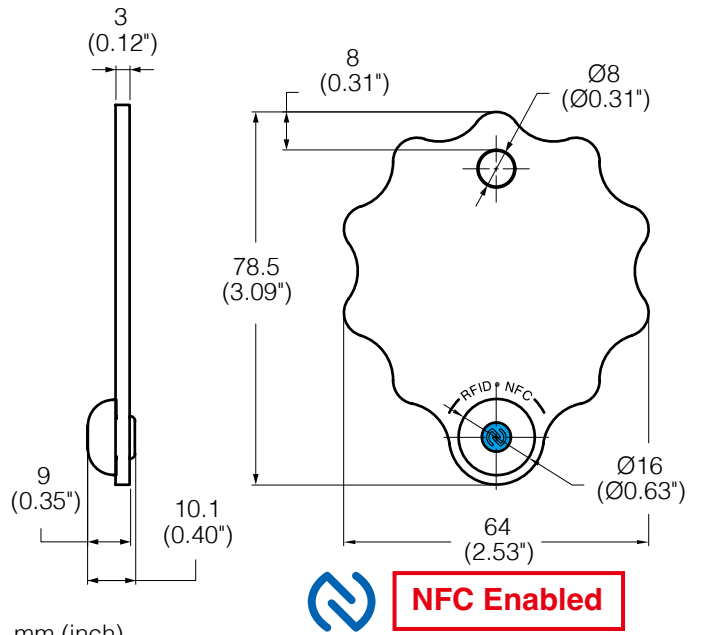

mm (inch)
weight: 34g (1.2oz)

Features:

- By using the Supra Digital Chips with a third-party asset management application to achieve product traceability, manufacturer authentication and digitized product information.
- NFC enabled mobile device or smart phone (iOS 14 or greater required/ Android 12 or greater required) can be used as reader.
- Unique design of proprietary wafer-antenna chip construction.

Application:

Lifting Chain Sling

Functionality	
RF Protocol	ISO 15693
Operating Frequency	HF - 13.56 MHz
Memory Configuration	UID 16 bits, User 2K bits
R/W Capability	Read / Write
Performance	
Read Range	Maximum to 5 mm [0.2"]
Quality Guarantee	100 %
Orientation	Front Face Read
Physical	
Materials	Aluminum [Anodizing]
Mounting System	Universal Use
Operational	
Max Temperature Exposure	125 °C / 257 °F
Min Temperature Exposure	-30 °C / -22 °F
Continuous Max Service Temperature	125 °C / 257 °F
Continuous Min Service Temperature	-30 °C / -22 °F
Water and Ice Proof	Yes



Patent Number

- » Taiwan Patent: M573545
- » China Patent: ZL 201821589819.6
- » Japan Patent: 3219858
- » United States Patent: 10607128

- » German Patent: 602018032891.2
- » Italy Patent: 3627396
- » UK Patent: 3627396

- » Taiwan Patent: 1638765
- » China Patent: ZL 2017 1 0821524.0
- » United States Patent: 10235617

- » United States Patent: 11305844
- » Japan Patent: 3220091

Item No. 13283
SupraDA Tag, DNV Sling Tag

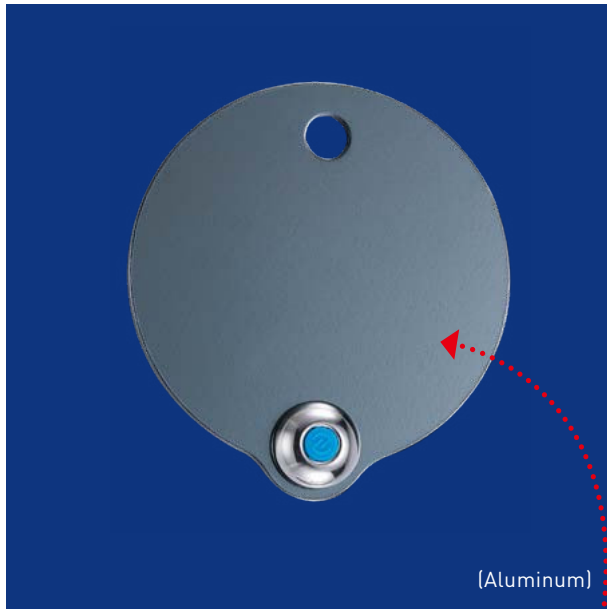

[Aluminum]

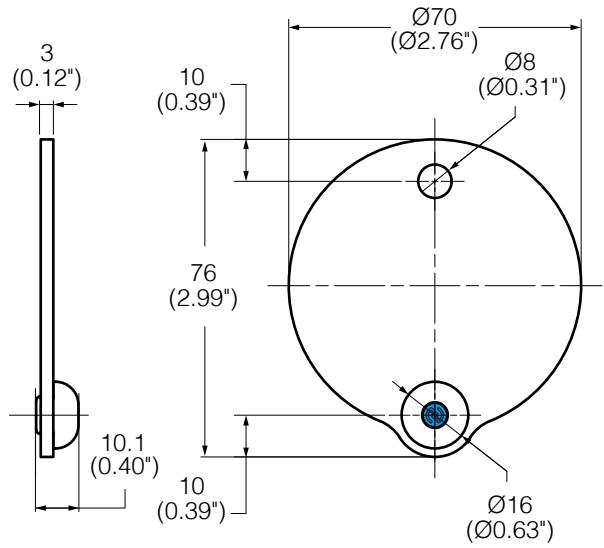

NFC Enabled

Custom Logo, Custom Content

Features:

- By using the Supra Digital Chips with a third-party asset management application to achieve product traceability, manufacturer authentication and digitized product information.
- NFC enabled mobile device or smart phone (iOS 14 or greater required/ Android 12 or greater required) can be used as reader.
- Unique design of proprietary wafer-antenna chip construction.

Application:

DNV 2.7-1 Lifting Sling

Functionality	
RF Protocol	ISO 15693
Operating Frequency	HF - 13.56 MHz
Memory Configuration	UID 16 bits, User 2K bits
R/W Capability	Read / Write
Performance	
Read Range	Maximum to 5 mm (0.2")
Quality Guarantee	100 %
Orientation	Front Face Read
Physical	
Materials	Aluminum (Anodizing)
Mounting System	Universal Use
Operational	
Max Temperature Exposure	125 °C / 257 °F
Min Temperature Exposure	-30 °C / -22 °F
Continuous Max Service Temperature	125 °C / 257 °F
Continuous Min Service Temperature	-30 °C / -22 °F
Water and Ice Proof	Yes



Patent Number

- » Taiwan Patent: M573545
- » China Patent: ZL 201821589819.6
- » Japan Patent: 3219858
- » United States Patent: 10607128



- » German Patent: 602018032891.2
- » Italy Patent: 3627396
- » UK Patent: 3627396

- » Taiwan Patent: 1638765
- » China Patent: ZL 2017 1 0821524.0
- » United States Patent: 10235617

- » United States Patent: 11305844
- » Japan Patent: 3220091

SupraX



CE₀₅₉₈ UK_{CA}₁₁₈₀  II 2G Ex ib IIC T 4 Gb
CE₀₅₉₈ UK_{CA}₁₁₈₀  II 2D Ex ib IIC T_{135°C} Db



SupraX Introduction

ATEX stands for the French abbreviation "ATmospheres EXplosibles" and consists of two EU directives describing what equipment and work environment is allowed in an environment with an explosive atmosphere.

According to these directives, only devices, systems and components which fulfil the ATEX product directives may be used in potentially explosive areas from 2003 onwards. These directives contain the basic safety requirements that must be adhered to and verified by means of the relevant conformity declarations.

SupraX series stand for ATEX, IECEx and UKEx certifications are suitable for use in explosive atmospheres, with these standards accepted in most regions worldwide.

SupraX has all ATEX approvals for use in Zone 1/21, which means SupraX can be used in all areas in which potentially explosive atmospheres such as dust or gas occur, and serve to improve the safety and health of workers who may be exposed to these explosive situations.

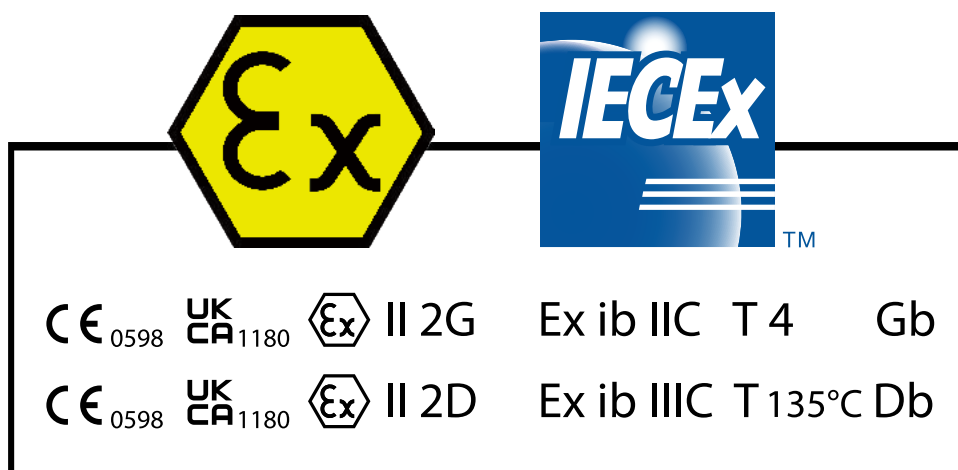

Item No. 53241

Ex SupraTag, SupraX-241



(Bronze)

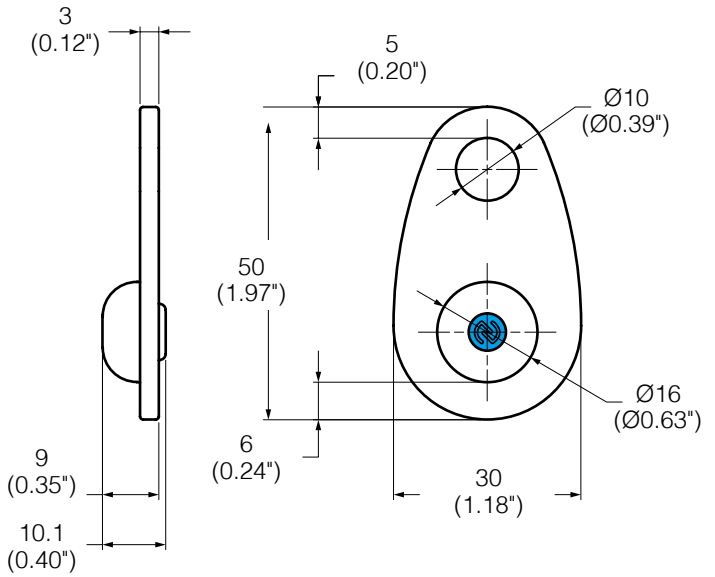

mm (inch)
weight: 35.5g (1.25oz)



NFC Enabled

Features:

- By using the Supra Digital Chips with a third-party asset management application to achieve product traceability, manufacturer authentication and digitized product information.
- NFC enabled mobile device or smart phone (iOS 14 or greater required/ Android 12 or greater required) can be used as reader.
- Unique design of proprietary wafer-antenna chip construction.

Application:

Universal



Functionality	
RF Protocol	ISO 15693
Operating Frequency	HF - 13.56 MHz
Memory Configuration	UID 16 bits, User 2K bits
R/W Capability	Read / Write
Performance	
Read Range	Maximum to 5 mm [0.2"]
Quality Guarantee	100 %
Orientation	Front Face Read
Physical	
Materials	Bronze (Electroplating)
Mounting System	Universal Use
Operational	
Max Temperature Exposure	125 °C / 257 °F
Min Temperature Exposure	-30 °C / -22 °F
Continuous Max Service Temperature	125 °C / 257 °F
Continuous Min Service Temperature	-30 °C / -22 °F
Water and Ice Proof	Yes

Patent Number

- » Taiwan Patent: M573545
- » China Patent: ZL 201821589819.6
- » Japan Patent: 3219858
- » United States Patent: 10607128
- » German Patent: 602018032891.2
- » Italy Patent: 3627396
- » UK Patent: 3627396
- » Taiwan Patent: 1638765
- » China Patent: ZL 2017 1 0821524.0
- » United States Patent: 10235617
- » United States Patent: 11305844
- » Japan Patent: 3220091

- Complies with SGS UL913 certification for Hazardous Location/Explosion Protection requirements. Please refer to product Item No.73241

Item No. 53282

Ex SupraLoop, SupraX-282

Certificate Pending

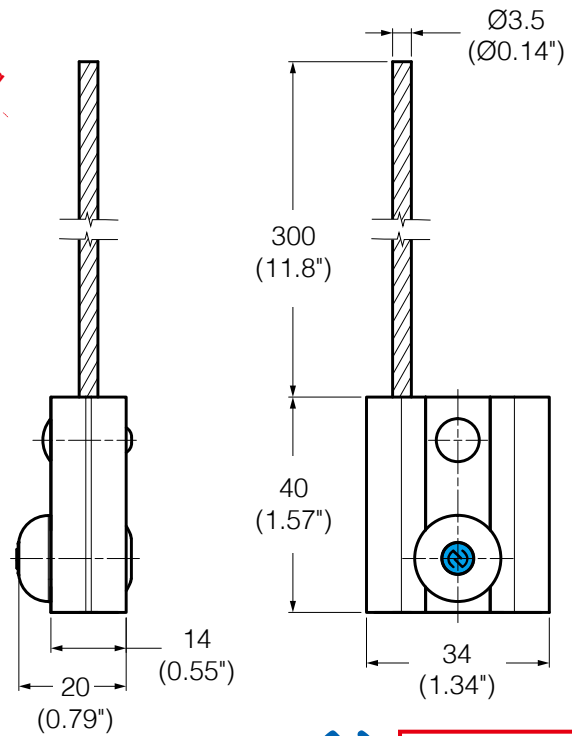

mm (inch)
weight: 47g (1.66oz)



NFC Enabled

Features:

- It can be installed without tools.
- The 7x19 stainless steel wire rope with a diameter of 3.5mm is strong, flexible, and convenient to use. The tensile strength of the wire rope is greater than 10kN.
- By using the Supra Digital Chips with a third-party asset management application to achieve product traceability, manufacturer authentication and digitized product information.
- NFC enabled mobile device or smart phone (iOS 14 or greater required/ Android 12 or greater required) can be used as reader.
- Unique design of proprietary wafer-antenna chip construction.

Application:

Universal

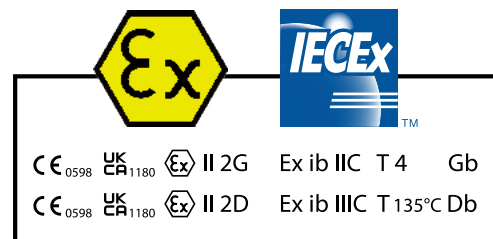

Functionality	
RF Protocol	ISO 15693
Operating Frequency	HF - 13.56 MHz
Memory Configuration	UID 16 bits, User 2K bits
R/W Capability	Read / Write
Performance	
Read Range	Maximum to 5 mm (0.2")
Quality Guarantee	100 %
Orientation	Front Face Read
Physical	
Materials	Stainless Steel (Polish)
Mounting System	Universal Use
Operational	
Max Temperature Exposure	125 °C / 257 °F
Min Temperature Exposure	-30 °C / -22 °F
Continuous Max Service Temperature	125 °C / 257 °F
Continuous Min Service Temperature	-30 °C / -22 °F
Water and Ice Proof	Yes



Patent Number

- » Taiwan Patent: M573545
- » China Patent: ZL 201821589819.6
- » Japan Patent: 3219858
- » United States Patent: 10607128
- » German Patent: 602018032891.2
- » Italy Patent: 3627396
- » UK Patent: 3627396
- » Taiwan Patent: 1638765
- » China Patent: ZL 2017 1 0821524.0
- » United States Patent: 10235617
- » United States Patent: 11305844
- » Japan Patent: 3220091

Item No. 53273

Ex Supra HoseTag, SupraX-273

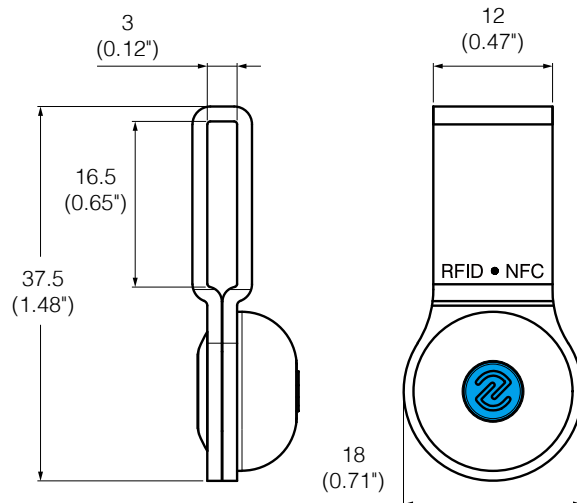

mm (inch)
weight: 20g (0.71oz)



NFC Enabled

Features:

- By using the Supra Digital Chips with a third-party asset management application to achieve product traceability, manufacturer authentication and digitized product information.
- NFC enabled mobile device or smart phone (iOS 14 or greater required/ Android 12 or greater required) can be used as reader.
- Unique design of proprietary wafer-antenna chip construction.

Application:

Pipeline, Hose, Valve, Wire Rope Sling



Functionality	
RF Protocol	ISO 15693
Operating Frequency	HF - 13.56 MHz
Memory Configuration	UID 16 bits, User 2K bits
R/W Capability	Read / Write
Performance	
Read Range	Maximum to 5 mm [0.2"]
Quality Guarantee	100 %
Orientation	Front Face Read
Physical	
Materials	Bronze [Electroplating]
Mounting System	Universal Use
Operational	
Max Temperature Exposure	125 °C / 257 °F
Min Temperature Exposure	-30 °C / -22 °F
Continuous Max Service Temperature	125 °C / 257 °F
Continuous Min Service Temperature	-30 °C / -22 °F
Water and Ice Proof	Yes



Patent Number

- » Taiwan Patent: M573545
- » China Patent: ZL 201821589819.6
- » Japan Patent: 3219858
- » United States Patent: 10607128
- » German Patent: 602018032891.2
- » Italy Patent: 3627396
- » UK Patent: 3627396
- » Taiwan Patent: 1638765
- » China Patent: ZL 2017 1 0821524.0
- » United States Patent: 10235617
- » United States Patent: 11305844
- » Japan Patent: 3220091

- Complies with SGS UL913 certification for Hazardous Location/Explosion Protection requirements. Please refer to product Item No.73273

Item No. 53226

Ex SupraBolt, M8x20mm, SupraX-226

Certificate Pending

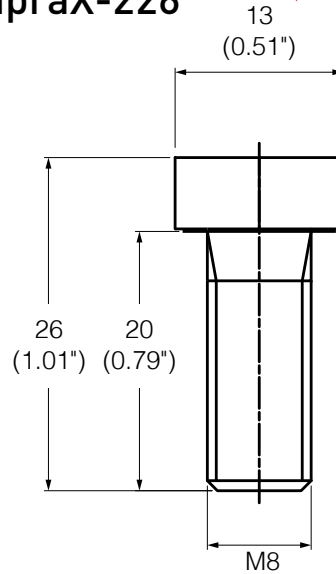

mm (inch)

weight: 10.6g (0.37oz)



NFC Enabled

Features:

- Metric Thread
- By using the Supra Digital Chips with a third-party asset management application to achieve product traceability, manufacturer authentication and digitized product information.
- NFC enabled mobile device or smart phone (iOS 14 or greater required/ Android 12 or greater required) can be used as reader.
- Unique design of proprietary wafer-antenna chip construction.

Application:

Engineering Equipment, Machine

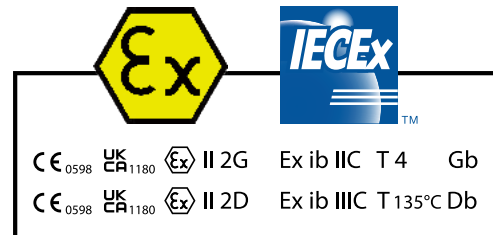

Functionality	
RF Protocol	ISO 15693
Operating Frequency	HF - 13.56 MHz
Memory Configuration	UID 16 bits, User 2K bits
R/W Capability	Read / Write
Performance	
Read Range	Maximum to 5 mm [0.2"]
Quality Guarantee	100 %
Orientation	Front Face Read
Physical	
Materials	Stainless Steel (Polish)
Mounting System	Universal Use
Operational	
Max Temperature Exposure	125 °C / 257 °F
Min Temperature Exposure	-30 °C / -22 °F
Continuous Max Service Temperature	125 °C / 257 °F
Continuous Min Service Temperature	-30 °C / -22 °F
Water and Ice Proof	Yes



Patent Number

- » Taiwan Patent: M573545
- » China Patent: ZL 201821589819.6
- » Japan Patent: 3219858
- » United States Patent: 10607128
- » German Patent: 602018032891.2
- » Italy Patent: 3627396
- » UK Patent: 3627396
- » Taiwan Patent: 1638765
- » China Patent: ZL 2017 1 0821524.0
- » United States Patent: 10235617
- » United States Patent: 11305844
- » Japan Patent: 3220091

Item No. 53228

Certificate Pending

Ex SupraBolt, 5/16x3/4" SupraX-228

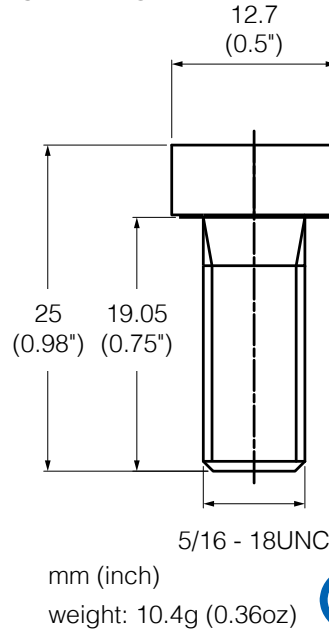

Features:

- UNC Thread
- By using the Supra Digital Chips with a third-party asset management application to achieve product traceability, manufacturer authentication and digitized product information.
- NFC enabled mobile device or smart phone (iOS 14 or greater required/ Android 12 or greater required) can be used as reader.
- Unique design of proprietary wafer-antenna chip construction.

Application:

Engineering Equipment, Machine

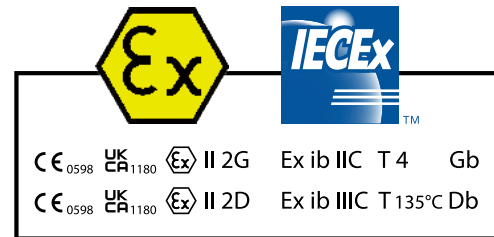

Functionality	
RF Protocol	ISO 15693
Operating Frequency	HF - 13.56 MHz
Memory Configuration	UID 16 bits, User 2K bits
R/W Capability	Read / Write
Performance	
Read Range	Maximum to 5 mm [0.2"]
Quality Guarantee	100 %
Orientation	Front Face Read
Physical	
Materials	Stainless Steel (Polish)
Mounting System	Universal Use
Operational	
Max Temperature Exposure	125 °C / 257 °F
Min Temperature Exposure	-30 °C / -22 °F
Continuous Max Service Temperature	125 °C / 257 °F
Continuous Min Service Temperature	-30 °C / -22 °F
Water and Ice Proof	Yes



Patent Number

- » Taiwan Patent: M573545
- » China Patent: ZL 201821589819.6
- » Japan Patent: 3219858
- » United States Patent: 10607128

- » German Patent: 602018032891.2
- » Italy Patent: 3627396
- » UK Patent: 3627396

- » Taiwan Patent: 1638765
- » China Patent: ZL 2017 1 0821524.0
- » United States Patent: 10235617

- » United States Patent: 11305844
- » Japan Patent: 3220091

Item No. 53248
SupraNail, Embedded Digital Chip

NEW

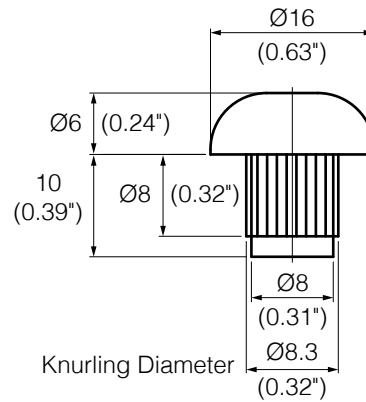

mm (inch)
weight: 10.6g (0.37 oz)



NFC Enabled

Features:

- Embedded Digital Chip
- By using the Supra Digital Chips with a third-party asset management application to achieve product traceability, manufacturer authentication and digitized product information.
- NFC enabled mobile device or smart phone (iOS 14 or greater required/ Android 12 or greater required) can be used as reader.
- Unique design of proprietary wafer-antenna chip construction.

Application:

Engineering Equipment, Machine

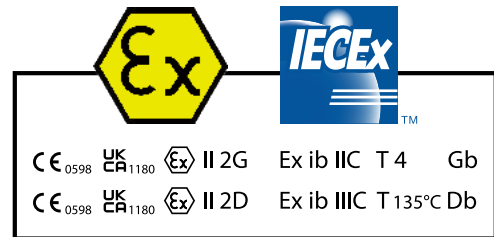

Functionality	
RF Protocol	ISO 15693
Operating Frequency	HF - 13.56 MHz
Memory Configuration	UID 16 bits, User 2K bits
R/W Capability	Read / Write
Performance	
Read Range	Maximum to 5 mm [0.2"]
Quality Guarantee	100 %
Orientation	Front Face Read
Physical	
Materials	Stainless Steel (Polish)
Mounting System	Universal Use
Operational	
Max Temperature Exposure	125 °C / 257 °F
Min Temperature Exposure	-30 °C / -22 °F
Continuous Max Service Temperature	125 °C / 257 °F
Continuous Min Service Temperature	-30 °C / -22 °F
Water and Ice Proof	Yes



Patent Number

- » Taiwan Patent: M573545
- » China Patent: ZL 201821589819.6
- » Japan Patent: 3219858
- » United States Patent: 10607128
- » German Patent: 602018032891.2
- » Italy Patent: 3627396
- » UK Patent: 3627396
- » Taiwan Patent: 1638765
- » China Patent: ZL 2017 1 0821524.0
- » United States Patent: 10235617
- » United States Patent: 11305844
- » Japan Patent: 3220091

Item No. 53263

Ex SupraPlate, SupraX-263

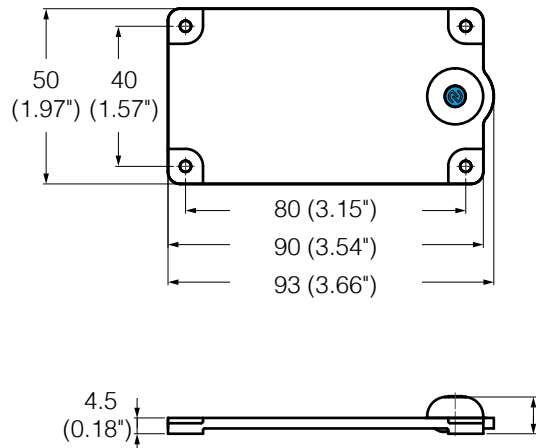

mm (inch)
weight: 44g (1.55oz)



NFC Enabled

Features:

- By using the Supra Digital Chips with a third-party asset management application to achieve product traceability, manufacturer authentication and digitized product information.
- NFC enabled mobile device or smart phone (iOS 14 or greater required/ Android 12 or greater required) can be used as reader.
- Unique design of proprietary wafer-antenna chip construction.

Application:

Engineering Equipment, Machine

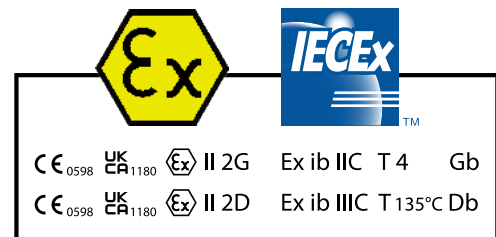

Functionality	
RF Protocol	ISO 15693
Operating Frequency	HF - 13.56 MHz
Memory Configuration	UID 16 bits, User 2K bits
R/W Capability	Read / Write
Performance	
Read Range	Maximum to 5 mm [0.2"]
Quality Guarantee	100 %
Orientation	Front Face Read
Physical	
Materials	Aluminum (Anodizing)
Mounting System	Universal Use
Operational	
Max Temperature Exposure	125 °C / 257 °F
Min Temperature Exposure	-30 °C / -22 °F
Continuous Max Service Temperature	125 °C / 257 °F
Continuous Min Service Temperature	-30 °C / -22 °F
Water and Ice Proof	Yes

Patent Number

- » Taiwan Patent: M573545
- » China Patent: ZL 201821589819.6
- » Japan Patent: 3219858
- » United States Patent: 10607128
- » German Patent: 602018032891.2
- » Italy Patent: 3627396
- » UK Patent: 3627396
- » Taiwan Patent: 1638765
- » China Patent: ZL 2017 1 0821524.0
- » United States Patent: 10235617
- » United States Patent: 11305844
- » Japan Patent: 3220091

Item No. 50732
Ex Cable Tie. 1/2" x 11.8"

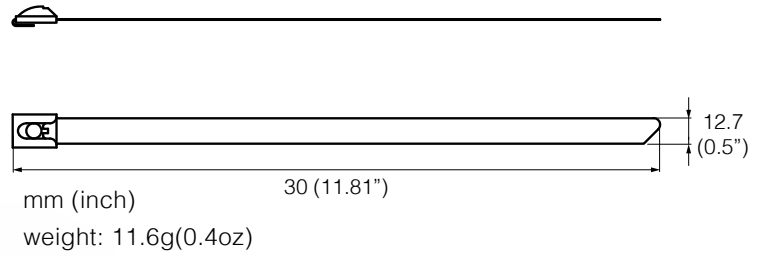

CE₀₅₉₈ UK₁₁₈₀ Ex II 2G Ex ib IIC T 4 Gb
 CE₀₅₉₈ UK₁₁₈₀ Ex II 2D Ex ib IIC T 135°C Db

Features:

- Material: Stainless steel
- Certified by UL and ISO 9001 for quality assurance
- Features a rapid automatic locking mechanism for easy hand installation. Can also be installed using tools.
- Suitable for outdoor environments.





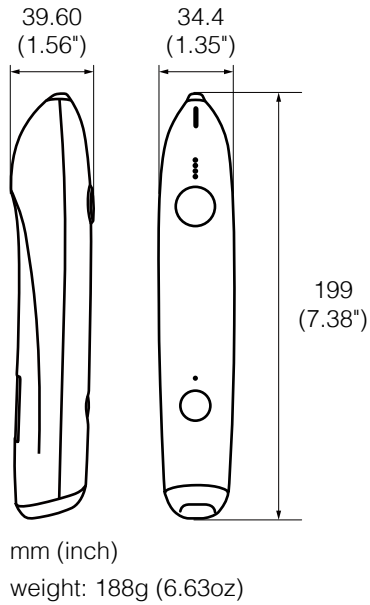

Item No. 1735 SupraTooth, Reader

- Applied with HF RFID tag chips Based on the ISO 15693 for reading.
- Read Count: 1,000 entries when fully charged.
- Indicator light, Alert Sound when operating.
- Compliance: FCC, CE, TELEC, NCC.

Functionality	
Supported Standards / Tags	ISO 15693
Working Voltage (Charging)	5V DC, 0.5A
Working Frequency	HF - 13.56 MHz
USB Port	Type C
Physical	
Material and Color	PC, White
Data Transfer Interface	HID Bluetooth
Battery type & Capacity	Lithium battery, 5800 mAh
Operational	
Working Temperature	Charging: 10°C~45°C Discharging: -20°C~60°C
Storage temperature	Less than 3 months -20~40°C 75%RH max
Dimensions	
Product Net Weight	188g (6.63oz)
Product Size	198 x 34 x 40mm

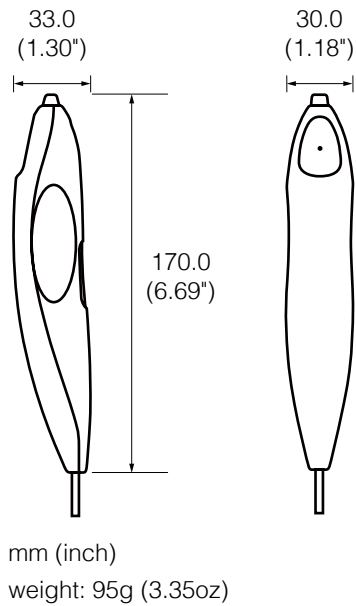

Item No. 1724 SupraPin, Reader

- Applied with any Digital Chips for fast reading.
- Easy to plug-n-play.
- Connects directly to USB ports and send data as keystrokes.
- Compatibility with Windows and Macintosh.
- Easy to apply on the production line.

Functionality	
Working Voltage	5V DC 
Working Frequency	HF - 13.56 MHz
USB Port	Type-A
Physical	
Material and Color	ABS, white
Wire Length	1.8 m
Operational	
Working Temperature	-20 ~ 60 °C
Storage Temperature	0 ~ 60 °C
Dimensions	
Product Net Weight	95g [3.35oz]
Product Size	170 x 30 x 35 mm

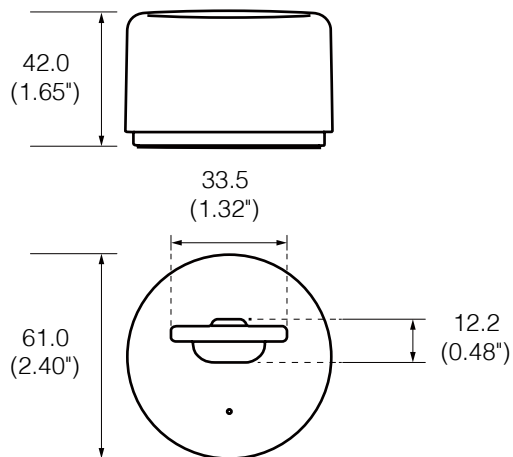

mm (inch)
weight: 86g (3.03oz)



Item No. 1762

SupraHana, Reader

- Compatible with SupraTag.
- Applied with YOKE SupraTag for fast reading.
- Easy to plug-n-play.
- Connects directly to USB ports and send data as keystrokes.
- Compatibility with Windows and Macintosh.
- Placed anywhere on the desktop.

Functionality	
Working Voltage	5V DC 
Working Frequency	HF - 13.56 MHz
USB Port	Type-A
Physical	
Material and Color	ABS, white
Wire Length	1.8 m
Operational	
Working Temperature	-20 ~ 60 °C
Storage Temperature	0 ~ 60 °C
Dimensions	
Product Net Weight	86g (3.03oz)
Product Size	61 x 61 x 42 mm

**TECH
FOR
SAFETY**

YOKE INDUSTRIAL CORP.

www.yoke.net