



Safehold
HEIGHT SAFETY & LIFTING GEAR

SafePod Tripod Instruction Manual

Models of device covered

40301

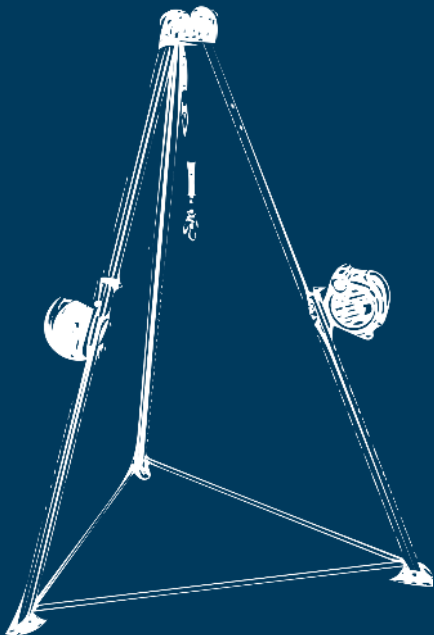

Note: For Declaration of Conformity See Page 23

Read and understand instructions before using this equipment

Do not throw instructions away

Designed in the UK

SHUM-045 Iss.01

Contents

4

About & Warning

5

General Use

6-9

Specifications

18-19

Examination &
Maintenance

20

Labelling



***User must read,
understand and observe
these instructions for use.***

10-15

Operations and use

16-17

Standards and
legislation

21

Service Log Table

22

Inspection Records
& Schedule

23

Declaration
of Conformity

ABOUT & WARNING

The SafePod is a passive fall arrest device. The device is designed to be used above structures and confined entry areas where other attachment is not possible. The Safepod is totally portable and is therefore a temporary anchorage. In the event of a fall the Tripod will provide a tested anchorage and a secondary anchorage for rescue if required. If in any doubt please clarify application with Safehold Technical Support.

 **Warning :** Working at height is a very dangerous activity which may lead to severe injury or fatality. We advise that you personally assume the responsibility to learn the use and the safety measures that apply to this equipment. Remember that there is no better "instruction" than that of a trained instructor. Train in the use of this device, verify that you have fully understood how it works and if in any doubt, please ask a competent person!

Don't make any alterations or additions to the equipment without the manufacturer's prior written consent. Any repair shall only be made by the manufacturer.

The products shall not be used outside of its limitations, or for any purpose other than that for which it is intended.

It is essential for the safety of the user that if the product is re-sold outside of the UK, the reseller shall provide instructions for use, for maintenance, for periodic examination and for repair in the language of the country in which the product is to be used.

If there is reason to doubt your fitness to safely absorb the shock from a fall arrest, please consult your doctor. Age and fitness seriously affect a worker's ability to withstand falls. Pregnant women or minors must not use it.



User must read, understand and observe these instructions for use.



GENERAL USE

All warnings and instructions must be provided to the authorised user. They must be read and understood in their entirety. Failure to use the equipment properly can result in serious injury or death. If in doubt, contact Safehold Ltd. for advice.

All authorised users must reference the relevant local standards to which the device complies (e.g. EN795:2012). Refer to device labelling for device compliance.

Before using the Tripod, the worker must be trained in the use and application limits of the equipment, proper hookup, anchoring and tie-off techniques, methods of use and proper methods of inspection and storage.

Ensure working area is free from hazards and obstructions that could interfere with the working of the device or cause harm to the user.

Inspect all equipment before each use as per the manufacturer's instructions.

All equipment should be inspected on a regular basis by a competent person.

A competent person must ensure the systems compatibility will not

allow accidental disengagement.

Any equipment must be as the manufacturer intended. Do not use altered or modified equipment.

Repairs must only be carried out by the manufacturer or authorised service agent with written consent to do so.

Any product that has visual deformities, been subjected to a fall, deterioration or unusual wear should be destroyed and removed from service immediately.

A rescue plan with the means to implement it should be in place before using this equipment.

Fall protection equipment is designed for a specific use. Never use it for something it wasn't designed to do.

Environmental hazards should be considered when using this equipment.

Equipment should not be exposed to hazardous chemicals. Inspection intervals may need to be more frequent in such environments. If in doubt contact **SAFEHOLD LTD** for advice.

Always ensure a potential fall path is free from obstructions and has a large enough ground clearance. Never remove a products label as

it contains information important to the use of the device. If the label is missing remove the device from service immediately.

GENERAL FEATURES AND SPECIFICATIONS

- One piece cast heat treated alloy head
- Recess label protection panel
- 2 x internal pulleys
- 1 x swivel anchor
- Patent Pending Auto Lock Rota Collar
- One hand release and open
- Cast alloy feet with EPDM rubber footpad
- General Construction: Aluminium (6061-T6); Hardware: Stainless Steel.
- Finish: Powder coated blue and anodised aluminium.
- User capacity: 140kg (250kg for two persons)
- Goods capacity: 250kg
- 15kg device weight
- Conforms to EN795 TYPE B 2012



DIMENSIONS

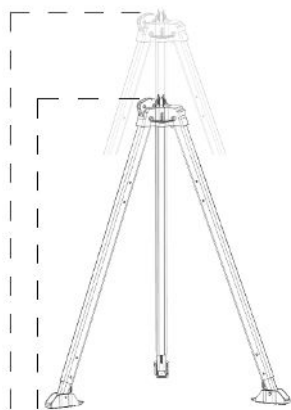

Height:

- MIN: 1.4m
- MAX: 2.3m

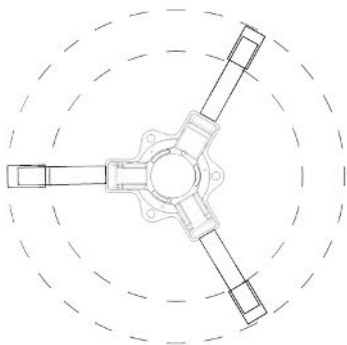

Diam:

- MIN: 1.5m
- MAX: 2.1m



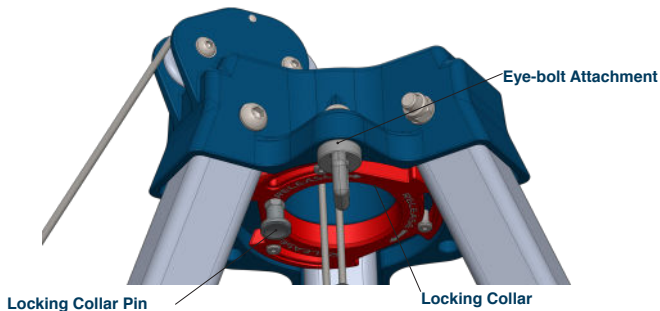

Risk Assessment

The SafePod has been designed to protect against falls from height of a, suspended worker being raised or lowered (potentially in a confined space), the top man operating the winching/rescue equipment or a

simultaneous fall of up to two users anchored to the same tripod. To facilitate this a number of Safehold approved fall arrest and rescue equipment can be connected to the tripod.

The SafePod and RTFA-R (31001) are designed for rescue use only. If the device is to be used as a primary man riding winch Safehold recommend the use of a secondary rescue device. The

device is designed to be used in Free Running mode and in the event of a fall the user can be rescued via the winching facility. For advice or further information contact Safehold.

IT IS ESSENTIAL TO ENSURE BEFORE USE THAT THE RECOMMENDATIONS SPECIFIC TO EACH PART ASSOCIATED WITH THIS PRODUCT ARE COMPLIED WITH, AS SPECIFIED IN THE MANUAL.

OPERATION & USE

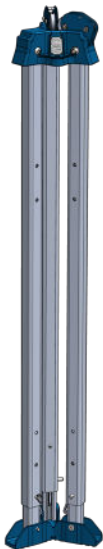

Fig. 1
Unpack tripod and stand upright.



Fig. 2
Release leg pins and slip up to desired height.

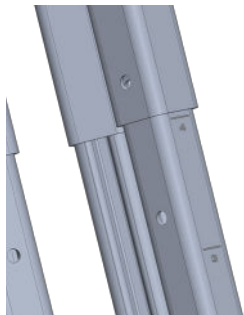

Fig. 2

See Markings on legs to indicate height.



Fig. 3

Lock individual legs with pins ensuring the marks on each leg match.

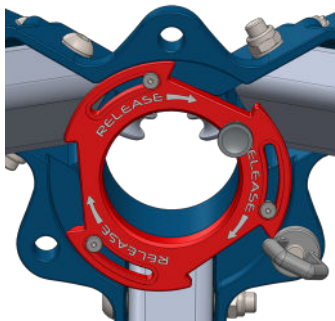
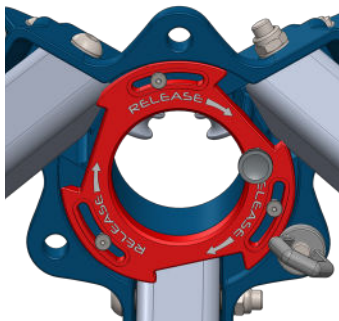

Fig. 4,5

Open the 3 legs using one as a pivot on the floor. The locking ring on the underside of the head will automatically lock into place.

Fig. 6

Please ensure that the pull trigger is completely closed and locked.

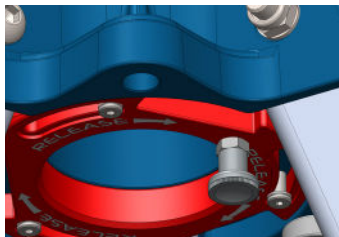



Fig. 7

Install anti splay webbing and ensure it is secure.

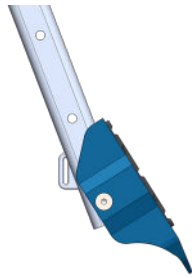

Fig. 8

Ensure feet are sitting flat on the ground. As shown in Fig.7 when used on hard ground, or fully folded back (Fig. 8) for use on soft ground.



Fig. 9

Adjust the width of the RTFA-R bracket to suit the tripod leg.



Fig. 10

Fix The RTFA-R bottom pin into the tripod and use as rest/pivot to attach the RTFA-R assembly to the tripod.



Fig. 11
Pivot the bracket and insert the second RTFA-R

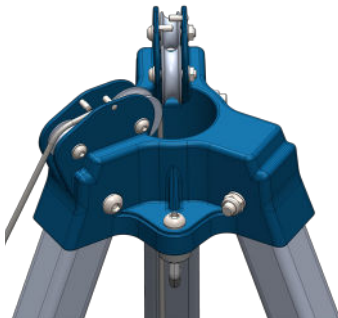

Fig. 12
Feed the cable through the staggered gap of the pins and the hook through the centre of the tripod head.

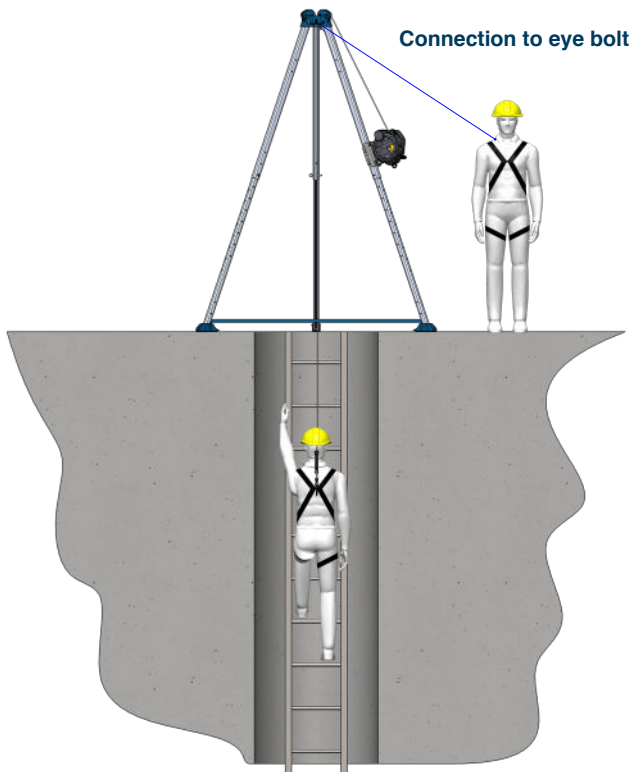

Fig. 13
If the device is to be used as a man riding device a Safehold winch will need to be added on the 2nd leg with pulleys on top.

Folding:

Reverse the above procedure ensuring that you release the spring loaded plunger and rotate the locking collar by hand into the disengaged position. The legs will then be able to be folded in.

CONFINED SPACE OPTION 1



When entering a confined space when a fixed access system is installed the user should use:

- 1 x Safepod tripod (40301)
- 1 x Safehold RTFA-R (31001)

The RTFA-R should be in free run mode and in the event of a fall the device will automatically lock on and then the winch can be engaged.

PLEASE NOTE THAT THE RTFA-R IS NOT INTENDED TO BE USED AS A CONTINUOUS WINCH, ONLY AS A RETRIEVAL DEVICE IN EMERGENCY SITUATIONS.

CONFINED SPACE OPTION 2

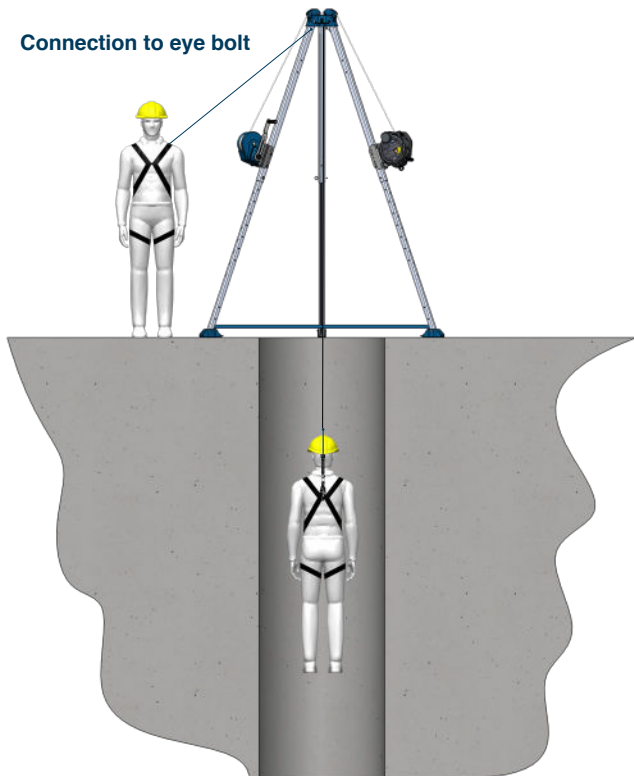

When entering a confined space when there is no fixed access system and there is a need to lower the user down under control, you should use:

- 1 x Safepod tripod (40301)
- 1 x Safehold RTFA-R (31001)
- 1 x Safehold Work Winch (40401)

The winch is your primary lowering device and in the event of a fall the RTFA-R will automatically lock on and the winch can be engaged.

OPERATION & USE CONTINUED

Warning:

Always follow the operating instructions and procedures recommended by the manufacturers of all associated equipment i.e. Harness, RTFA-R and fall arrest lanyard.

Before each use of the Tripod, carefully inspect it according to the Checklist (page 22).

Friendly reminder:

Do not alter or intentionally misuse this equipment.

Some subsystem and component combinations may interfere with the operation of this equipment.

Purpose:

This product is part of a personal fall arrest, restraint, work positioning, suspension, or rescue system.

A personal fall arrest system (PFAS) is typically composed of an anchorage and a full body harness (SHBH), with a connecting device, i.e. a shock absorbing lanyard (SHFAL), or a self-retracting device (SRL/RTFA) or a restraint lanyard (SHRL) attached to the dorsal D-ring of the SHBH.

Maximum 2 workers can be secured to the Tripod.

Do not use this equipment when in doubt of your fitness to safely absorb shocks from fall arrest. Age and fitness seriously affect the worker's ability to withstand falls. Pregnant women or minors must not use the Safepod Tripod.

Use caution when using this equipment around moving machinery, electrical hazards, chemical hazards, sharp edges.

Restraint lanyards are designed for use in applications where falls may not occur.

Restraint lanyards may be used in conjunction with a harness in many situations where a combination of work mobility and restraint is required. (I.e. inspection work, general construction, maintenance work, oil production, confined space work, etc.)

A suitable rescue plan must be made in case of a fall and made available to everyone on site.



Fall arrest system:

The worker must be secured to the Tripod at all times by a proper fall arrest system consisting of a full body harness and a RTFA-R (Retractable type fall arrester-rescue)

Length of the RTFA or lanyard must be carefully selected so that the falling worker cannot contact any

lower level structure, floor etc. in the event of a fall.

The connectors of the Harness, RTFA-R or lanyard must be selected to prevent accidental disengagement from each other and the Tripod. When in doubt regarding the selection of Harness / RTFA-R; consult Safehold Ltd.

Anchorage:

The Tripod must be properly secured to a flat surface.

Swing Falls occur when the Anchorage is not directly above the point where the fall occurs.

The total vertical fall distance in a Swing Fall is greater than a direct

free fall. Select the length of the RTFA-R so that the falling worker cannot contact any lower level structure, floor etc. in the event of a fall.

The Employer must have a rescue plan and the ability to rescue the worker in the event of a fall.

Standards:

The EU type-examination (Module B) and conformity assessment procedure (Module D) were conducted by CCQS Certification Services Limited, Block 1 Blanchardstown Corporate Park, Ballycoolin Road, Blanchardstown, Dublin 15 D15 AKK1, Ireland (NB2834).

The products are compliant with Personal Protective Equipment (PPE) regulation (EU) 2016/425, the Regulation 2016/425 on personal

protective equipment as brought into UK law and amended, and the following standards.

The Safehold Tripod range has been designed to meet the requirements of EN795:2012 and PD CEN/TS16415:2013 Type B as a minimum

The EU declaration of conformity is accompanying each product.

PERIODIC EXAMINATION & MAINTENANCE

The safety of the users depends upon the continued efficiency and durability of the Safepod tripod.

Due to the complexity and safety critical knowledge required in the dismantling, re-assembly or assessment of the Tripod, after a fall; periodic examination shall be only conducted by Safehold Ltd. Or by a competent person authorised by Safehold Ltd. Strictly

Inspection:

This and any associated equipment must be visually inspected by a competent person when initially delivered to site, there after

The product must be inspected before and after use. A record card is printed at the back of this manual and should be updated after each routine inspection.

Follow the points laid down in the

Storage:

Storage in a central protected location allows assurance of inspection on issue and return

This tripod should be stored in a clean dry place where it

in accordance with Safehold Ltd. Periodic examination procedures.

Establish a periodic examination schedule conforming to the legislation, frequency of use, and environmental conditions. It is recommended that the periodic examination frequency be at least every 6 months.

checklist without deviation.

The supervisor must ensure that the equipment is being used correctly and that the user is aware of its safe use and inspection.

Additionally the supervisor must ensure that the site to which the device is to be used has been approved fit for use

And is in a good condition.

can be protected from damage by chemical attack and sharp objects. It should be stored with its instructions and record card at all times.

After use return to the store, Never leave the device lying around site.



Certification:

Ensure that device certification is current before use, the device must have been serviced within the last 6 months and 3 months if used in corrosive or off-shore environments.

If for any reason the inspection of this device shows signs

for concern or doubt then the device must be quarantined and removed from service immediately. Qualification should be sought from the supervisor and if Still concerned the device must be sent to the supplier, an approved service agent or the manufacturer for Service and re-calibration.

Cleaning & Lubrication:

The Tripod will function better and last longer if its kept clean and well lubricated.

Wash down the Tripod with fresh

water every month. When dry, spray WD40 lubricant or equivalent at all joints.

Do not force dry with heat.

IMPORTANT :

These instructions should be supplied to each person using this product. This device must be inspected according to SAFEHOLD's recommendations for safe use. Prior to each use it should be checked by the user

and at least once a year by the manufacturer or by an authorised person. The inspection should be recorded on the enclosed schedule. Connect only to fall arrest attachment of a full body harness.

Notes:

1. Failure of a worker to perform [before each use] inspection or failure of an inspection by a worker shall initiate the requirement for inspection by a competent person.
2. Failure of a competent person to perform inspections as

specified in this Table, or failure of an inspection by the competent person shall initiate product revalidation or disposal.



3. Determination of the type of use category shall be determined by a competent person.

This device must only be serviced by a trained and competent individual, Never attempt to service this device or tamper with its function in any way.

Labelling:

See below for the a typical Safepod label. All labels on the Safepod must be present and fully legible.

www.safe-hold.com	
Part No. 40301	
Serial No.	
Tripod	SP1 - SAFEPOD
D.O.M	
Iss. 0 Part No. 40302	
 Safehold Kent. England. ME10 3RY	
Always read & follow the instructions for use. IF IN DOUBT DO NOT USE!	
	CE 2834
EN795:2012/PD CEN TS 16415 2013 Type B	
MAX 2 users on Tripod	
Max total weight: 200kg	
Max user 140kg	
Max Goods Lifting: 250kg	

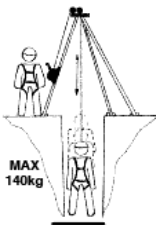



MAX 140kg

MAX 2 users on Tripod
Max total weight: 200kg
Max user weight: 140kg
Max Goods Lifting: 250kg



MAX 250kg

 **Safehold**
Iss. 0 Part No. 40302

Component	Inspection:	User	Competent Person
Tripod Head	Inspect the device for corrosion or damage.		
	Check the condition of the cable retention pins.		
	Check the sprung loaded locking ring self-engages when the legs are opened.		
	Check the condition of the pulley and eye-bolt attachment. Pulleys should run free, the eye-bolt must be swivel.		
Tripod Legs	Check condition of leg tubes for damage, corrosion bends and hole wear.		
	Check the leg pins for signs of wear or damage and replace wear necessary.		
Tripod Feet	Check rubber pads are fitted and not missing any fixings.		
General	Check whether all fasteners are secured properly.		
	Check the device opens and closes fully.		
Labels	All labels are present and fully legible		
Anti splay tape	Check the condition of the entire length and buckle of the anti-splay tape for damage.		
Associated Equipment	Additional Fall protection equipment that is used with the product is installed and inspected as per manufacturers instructions		
<p>If the product fails the inspection procedure remove from service immediately. Clearly tag the product "DO NOT USE" in the event of failure.</p>			
<p>Comments:</p>			



EU DECLARATION OF CONFORMITY

This declaration of conformity is issued under the sole responsibility of the manufacturer: SAFEHOLD LTD: 1-3 Eaves Court Bonham Drive, Sittingbourne, ME10 3RY.

Compliance@safe-hold.com +44 (0) 1795 668862

Model No. SP1

Product Code	Description	Model No.	Cert No.
40301	Safepod Tripod	SP1	CE-PC-230712-173-01-9A

The EU type-examination (Module B) and conformity assessment procedure (Module D) were conducted CCQS Certification Services Limited, Block 1 Blanchardstown Corporate Park, Ballycoolin Road, Blanchardstown, Dublin 15 D15 AKK1, Ireland (NB2834).

We hereby declare that the above referenced product, to which this declaration relates, is in conformity with the provisions of: -

**PPE Regulation 2016/425 - Standard EN 795:2012 Type B,
PD CEN/TS16415:2013 Type B**

SAFEHOLD LTD.

CE 2834

Name: Oliver Auston **Position:** CEO **Date:** 01/01/2024



Safehold
HEIGHT SAFETY & LIFTING GEAR

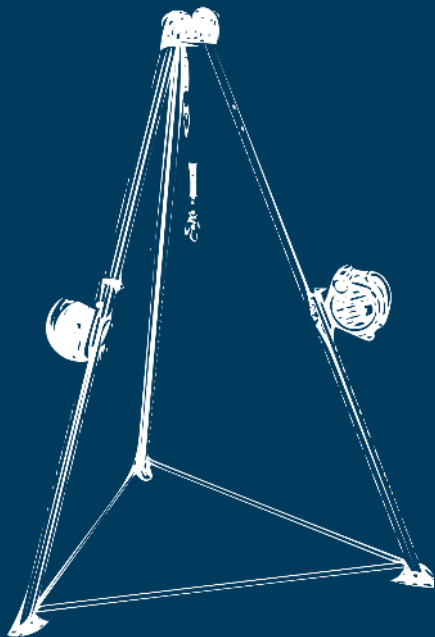

www.safe-hold.com